

High-quality and high efficiency top solid indexable Drill

TPDB Plus Drill

KORLOY
TECH-NEWS



TPDB Plus
Standard

TPDB-DS ^{new}
Medium / large diameter

TPDB-H ^{new}
H-Beam

- Improved productivity and excellent machining quality through stable machining
- Versatility in machining various surfaces, structural Steel, and medium / large diameter machining

High-quality and high efficiency top solid indexable Drill

TPDB Plus Drill

In various industries, there are demands of excellent performance and machining time reduction to improve machining efficiency. Thus, the demand for efficient cutting tools leads to a continuous increase.

To respond to these market demands, KORLOY launching the **TPDB Plus Drill**, a high quality and high-efficiency indexable Drill that enhances machining quality and production efficiency.

The **TPDB Plus Drill** with high helix flutes ensures smooth chip evacuation during machining, greatly enhancing hole surface finish, roundness, and machining quality. Additionally, **TPDBP-H** dedicated hole machining in structural Steel, and **TPDB-DS** for medium / large diameter Drilling provide multi-faceted usability across different industries.

The **TPDBP-H** insert with unique lowcutting resistance cutting edge improves centering and provides excellent machining quality even in vibrationprone machining environments byreducing machining load. In addition, the high helix angle applied flutes prevents vibration and unexpected tool breakage caused by chip blockage, thereby enhancing machining stability and productivity.

TPDB-DS is a Drill designed for machining medium/large diameter workpieces, applying a strong clamping structure. The specially designed clamping system and screw clamping method enablestable machining in high cutting load machining environments.

Additionally, the double-margin design provides excellent hole surface finish and precision. Highly precise and efficient top solid indexable Drill Excellent machinability.

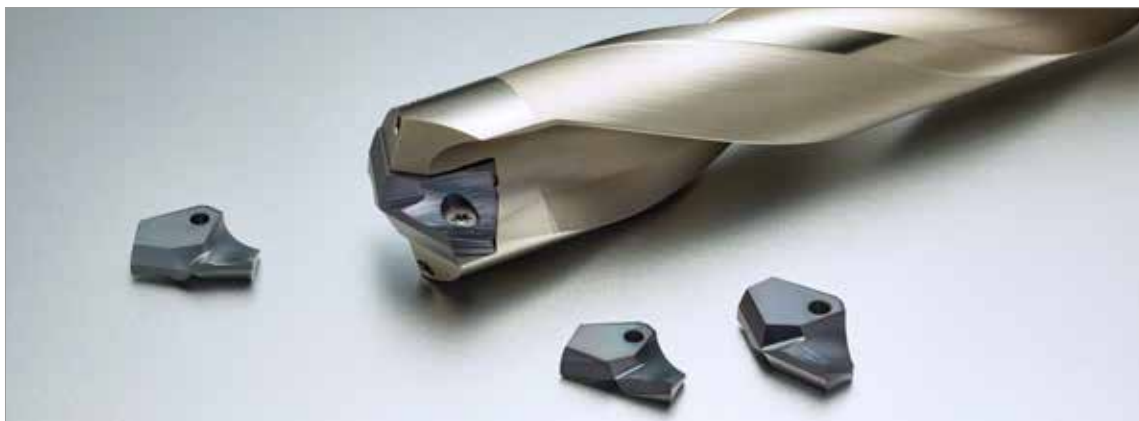

Excellent machinability

- Excellent hole machining performance with specified cutting edge designs per applications
- Good chip evacuation with high helix angle application

Improved productivity

- Reduced cycle time through tool simplification
- Durable holder with special surface treatment

Application range

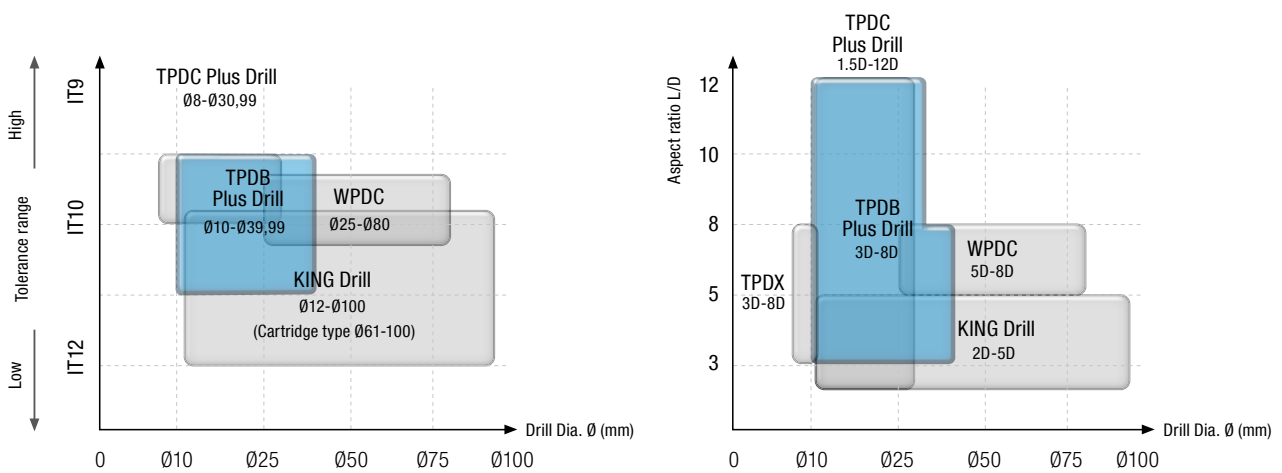

Tool		Application range					Workpiece material
		Drill (Ø)	Tolerance of hole	Surface finish (Ra)	Aspect ratio (Aspect ratio)	Tolerance of Drill dia.	
TPDB Plus Drill	TPDB Plus	10,0 - 32,99	0 - +0.1	≤ 2.0 µm	3, 5, 8, 10, 12	h7	P K
	TPDB-DS	33,0 - 39,99	0 - +0.2	≤ 2.5 µm	3, 5, 8		P K
	TPDBP-H	14,0 - 32,99	0 - +0.1	≤ 2.5 µm	3, 5, 8		P

Applicable industries

Generation of wind and nuclear power	Shipbuilding	Railway construction	Aircraft	Automobile

Indexable Drill selection guide

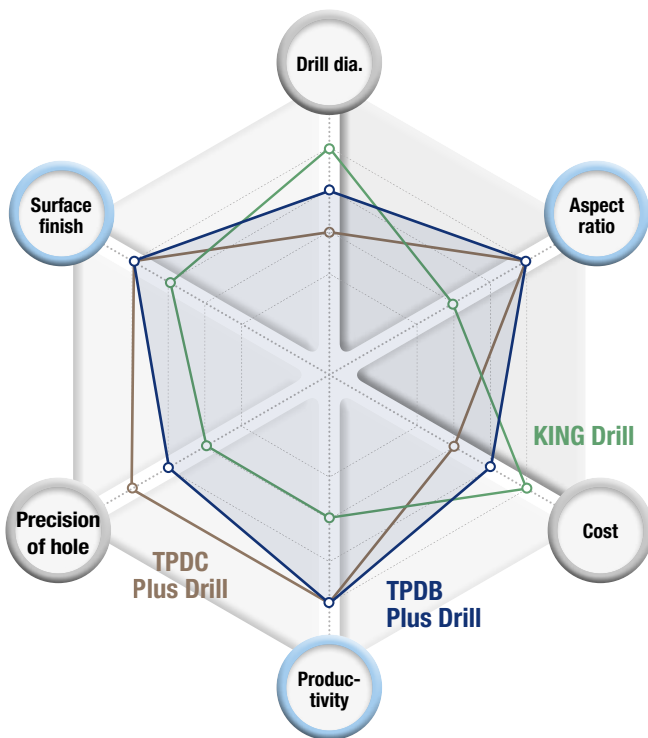

TPDB Plus Drill new

- Good surface finish
- High productivity
- 3D, 5D, 8D, 10D, 12D



TPDC Plus Drill

- One step clamping
- High precision of hole
- 1.5D, 3D, 5D, 8D, 10D, 12D







KING Drill

- 4 corners (central and peripheral)
- 2D, 3D, 4D, 5D



Tool	Drill Dia.	Aspect ratio	Cost	Productivity	Precision of hole	Surface finish
TPDB Plus Drill new	★★★	★★★★	★★★	★★★★	★★★	★★★★
TPDC Plus Drill	★★	★★★★	★★	★★★★	★★★★	★★★★
KING Drill	★★★★	★★	★★★★	★★	★★	★★★

TPDB Plus - types of damage to Drill and solutions

Scratches on the margin		
	Factor	<ul style="list-style-type: none"> Lack of coolant lubrication Lack of coolant in deep Drilling due to MQL system Bend of Drill due to improperly placed holder or using a long holder Low rigidity or large concentricity
	Solution	<ul style="list-style-type: none"> Use more coolant Place workpiece tightly and check the concentricity Check the precision of installment of Drill (below 0.03 mm) Reduce the cutting speed
Wear on the margin		
	Factor	<ul style="list-style-type: none"> Due to machining pure metal or heat resisting alloy Less back taper due to using a holder for a long time Unstable machining at the end of hole due to interruption Lack of coolant lubrication on the peripheral section of holder contacting workpiece
	Solution	<ul style="list-style-type: none"> Set up proper tool life and manage its usage Check the shape of machining part Check the kind and concentration of coolant
Chipping on the corner		
	Factor	<ul style="list-style-type: none"> Interrupted machining (end of hole is inclined or curved shape, junction hole the middle of hole.) Chattering in Drilling due to unstable clamping, low rigidity of machine or bending of Drill Chattering due to unstable clamping of Drill
	Solution	<ul style="list-style-type: none"> Check the part of machining Machine in lower cutting speed Place workpiece tightly Check the performance of the machine Check the precision of installment of Drill (below 0.03 mm)
Wear on the rake face		
	Factor	<ul style="list-style-type: none"> Low cutting speed Machining free-cutting Steel Erosion of chip and flute Lack of coolant lubrication
	Solution	<ul style="list-style-type: none"> Increase cutting speed Set a lower thinning angle Reduce the honing Use more coolant
Chipping on the rake face		
	Factor	<ul style="list-style-type: none"> Fracture on the cutting edge partially due to pre-treatment on the center of hole Unstable chip evacuation due to step Drilling and external coolant Chattering in Drilling and low precision of holder installment
	Solution	<ul style="list-style-type: none"> Check if there is pre-machining or not It is recommended to use internal coolant in step Drilling Check the state of clamping workpiece and the precision of Drill installment (below 0.03 mm)

TPDB Plus - Types of damage to workpiece and check points

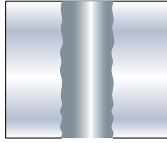
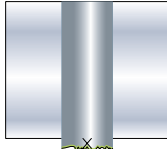
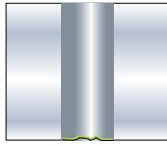
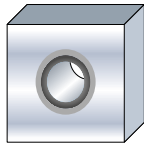
Poor surface finish (rough, scratch, etc.)		
	Factor	<ul style="list-style-type: none"> Low rigidity of machine and improperly clamped workpiece Large concentricity and lack of coolant
	Solution	<ul style="list-style-type: none"> Clamp the workpiece properly and check the concentricity Increase the amount and pressure of coolant
Remained lots of burr at the end of the Drilled hole		
	Factor	<ul style="list-style-type: none"> High feed and excessive honing of the cutting edge Exceeded cutting tool's tool life (too much wear and chipping)
	Solution	<ul style="list-style-type: none"> Reduce feed (especially at the end of hole) and use a new Drill Increase point angle or reduce honing
Flaking the end of the Drilled hole		
	Factor	<ul style="list-style-type: none"> Machining of low toughness materials as cast iron Rapid feed and excessive honing of the cutting edge Exceeded cutting tool's tool life (too much wear and chipping)
	Solution	<ul style="list-style-type: none"> Reduce the feed (especially at the end of hole) and use a new Drill Reduce honing on the cutting edge
Thermal deformation and oxidation of the end of the Drilled hole		
	Factor	<ul style="list-style-type: none"> Rapid feed and lack of coolant Excessive cutting load, exceeded cutting tool's tool life (too much wear and chipping)
	Solution	<ul style="list-style-type: none"> Reduce the feed and honing on the cutting edge Use more coolant and use a new Drill

Solutions for troubles

↑ Increase ↓ Decrease ○ Use

Trouble	Designation	Solution															
		Cutting condition					Tool shape					Grade		The others			
		vc	fn	Coolant	fn (in beginning)	Depth of cut	Relief angle	Point angle	Thinning angle	Honing	Flute width rate	Toughness	Hardness	Rigidity of machine	Chattering of machine	Fixing workpiece	Overhang
Chipping	<ul style="list-style-type: none"> Improper cutting conditions Low rigidity of tool Built-up edge Improper grade Chattering 	↓	↓	○			↓	↓	↑		↑		↑	↓	↑	↓	
Wear	Excessive cutting speed (wear on margin)	↓	↓	○								↑					
	Low cutting speed (wear in the center of Drill)	↑	↓	○								↑					
Fracture	<ul style="list-style-type: none"> Improper cutting conditions Too much cutting load Too long overhang Less rigidity of machine 	↓	↓	○	↓	↓							↑		↑	↓	
Poor chip evacuation	Improper cutting conditions		↓	○		↓					↑						
Poor surface finish	<ul style="list-style-type: none"> Built-up edge Chattering Improper cutting conditions 	↑	↓	○	↓		↓		↓				↑	↓	↑	↓	
Poor accuracy of hole	Low cutting speed (wear in the center of Drill)	↑	↓										↑	↓		↓	

TPDB Plus - Special Drill order form

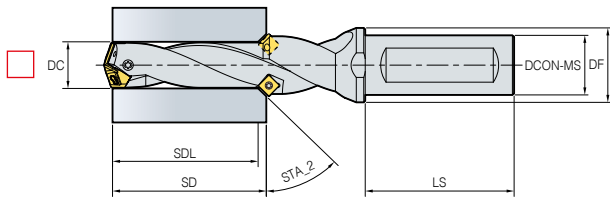
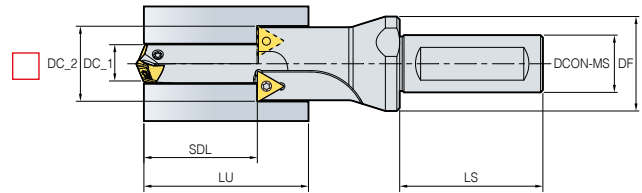
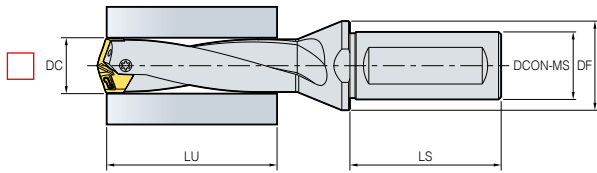
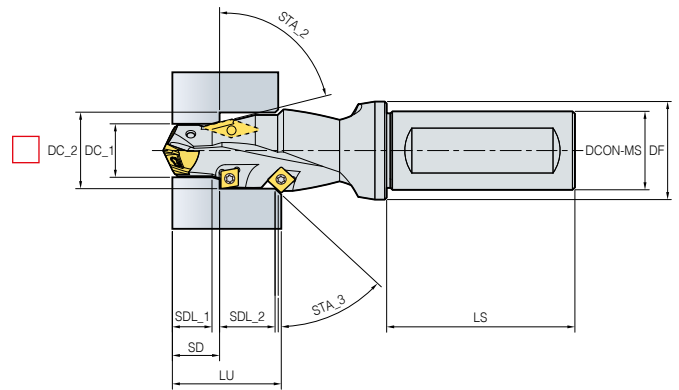
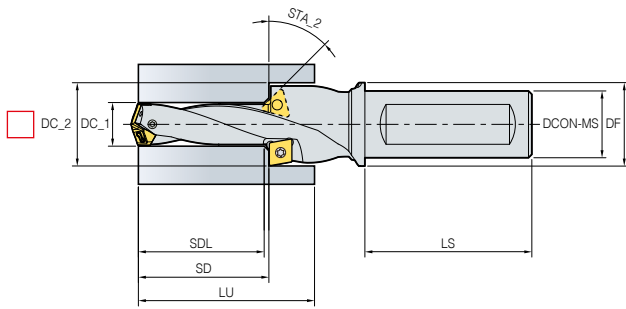

Hole type

- Blind hole Through hole

Coolant type

- Internal External

Special note

- Currently using tool
- Current cutting condition
 - n (rpm) or vc (m/min):
 - vf (mm/min) or fn (mm/rev):
 - Depth of cut, ap (mm):
- Standard of measuring tool life
- Currently using machine
 - Machining center:
 - General lathe:
 - CNC lathe:

Shank type

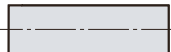
-  Plain

-  Flat

-  Weldon

-  Whistle Notch

TPDB Plus - Code system

Insert



Holder

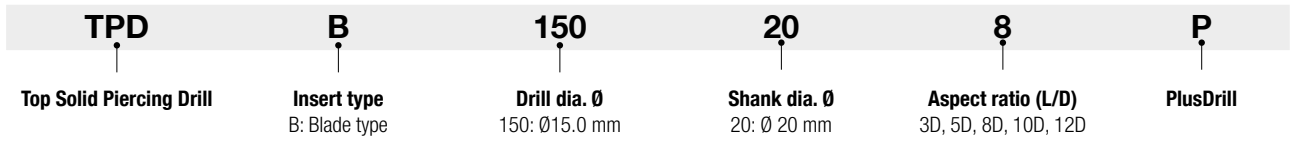

Features

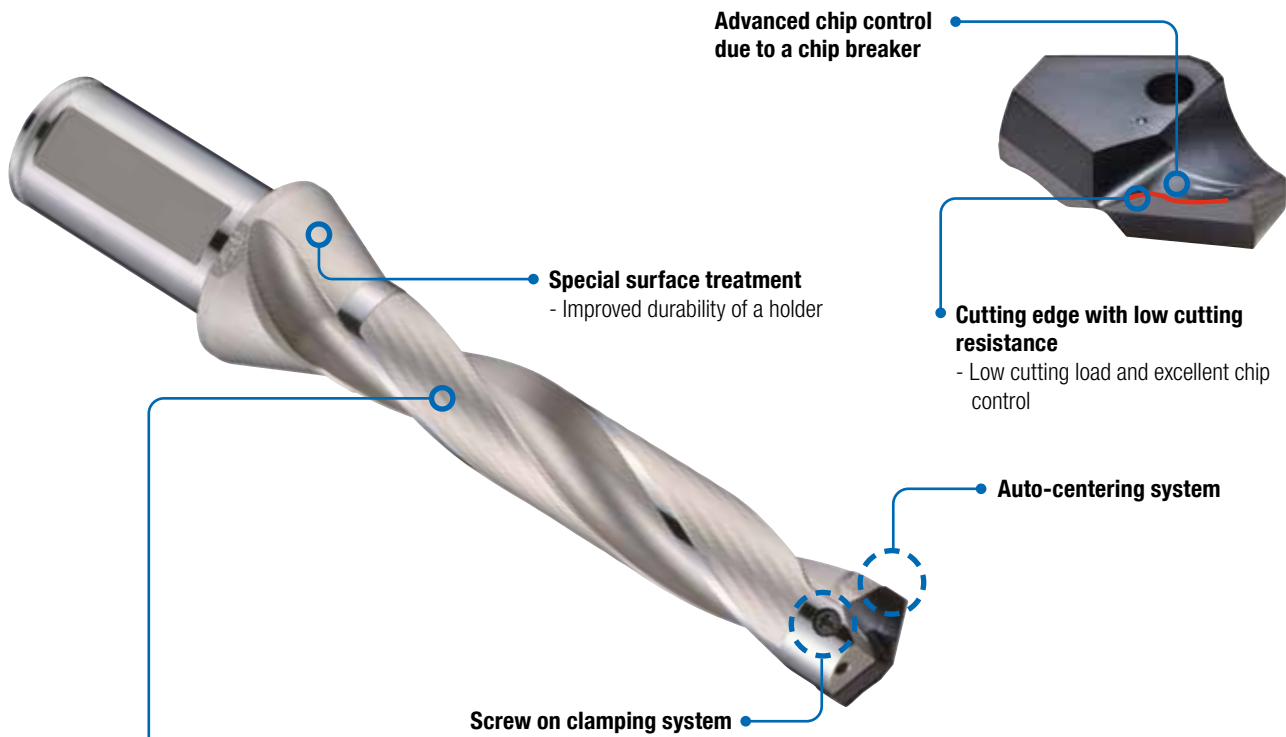

High helix angle

High productivity

- Stable chip evacuation realizes stable machinability
- Decreased cycle time by applying improved cutting conditions

Improvement in machining quality

- Good surface finish and regular size of the hole



20% higher productivity

Applying flute with higher helix angle than TPDB's



TPDB Plus - Run-out

Workpiece	Alloy steel (42CrMo4, HRC22)
Cutting condition	vc = 90 m/min · fn = 0,25 mm/rev ap = 120 mm · wett · 20 bar
Tool	Insert TPD250B (PC5300) Holder TPDB250-32-5-P (Drill dia. Ø = 25 mm)

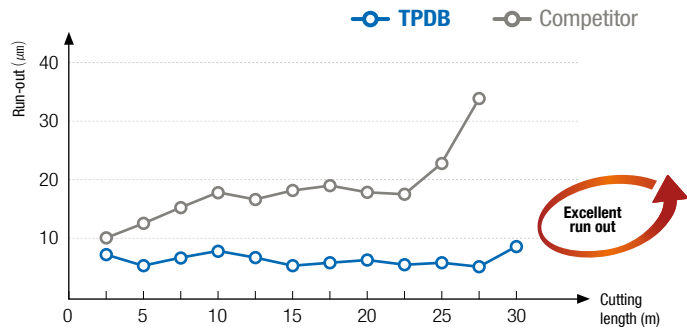

How to clamp an insert

Clamping an insert to a holder



- Put an insert on the tip seat of the holder.
- As the [Pic. 1], push the insert to the v-shaped groove of the holder.
- Screw and clamp the insert.

Changing the used insert to a new one



- Unscrew and separate the used insert from the holder.
- As the [Pic. 2], clean the insert seat.
- Put a new insert on the tip seat.
- As the [Pic. 3], clamp the insert pushing it with a hand not to separate from the holder.

Empfohlene Cutting condition

ISO	Workpiece				Specific cutting force (N/mm ²)	Brinell Hardness (HB)	Grade	vc (m/min)	Aspect ratio = 3D, 5D		
	Workpiece material	KS	ISO	fn (mm/rev)							
				Ø10-Ø16.9					Ø17-Ø26.9	Ø27-Ø32.9	
P	Carbon steel	C = 0.10 - 0.25%	SM15C SM25C	C15 C25	1500	90 - 200	PC5335 PC330P	80 - 140	0.30 - 0.15	0.35 - 0.20	0.40 - 0.25
		C = 0.25 - 0.55%	SM35C SM45C	C35 C45	1600	125 - 225	PC5335 PC330P	80 - 140	0.30 - 0.15	0.35 - 0.20	0.40 - 0.25
		C = 0.55 - 0.80%	SM58C	C60	1700	150 - 250	PC5335 PC330P	70 - 130	0.30 - 0.15	0.35 - 0.20	0.40 - 0.25
	Alloy steel ≤ 5%	non-hardened	SCM440	42CrMo4	1700	180	PC5300	80 - 140	0.35 - 0.18	0.38 - 0.23	0.43 - 0.28
		Hardened and Tempered	SCM445	-	2050	350	PC5300	50 - 100	0.35 - 0.18	0.38 - 0.23	0.43 - 0.28
	Alloy steel > 5%	Annealed	STD11	-	1950	200	PC5300	50 - 90	0.30 - 0.18	0.35 - 0.20	0.40 - 0.25
Tool steel		STD61	X40CrMoV5-1	3000	352	PC5300	40 - 80	0.30 - 0.18	0.35 - 0.20	0.40 - 0.25	
K	Gray cast iron		GC250 GC350	250 350	900	150 - 230	PC5300	80 - 140	0.35 - 0.18	0.40 - 0.20	0.45 - 0.25
	Ductile cast iron		GCD400 GCD500 GCD600	400-15 150-10 600-3	870	160 - 260	PC5300	70 - 130	0.35 - 0.18	0.40 - 0.20	0.45 - 0.25

In case of 8D, machine in 20 - 30% lower cutting conditions than the mentioned above, or machine the beginning of hole (1.5D) before Drilling.
In interrupted machining, reduce the feed to 0.1- 0.15 machining around the interrupted part.
Refer to the 'Recommended Drilling method' on the page 12 for Drilling of 10D - 12D.

TPDB Plus - Performance evaluation

Cutting load

Workpiece Alloy steel (42CrMo4, HRC22)

Cutting condition $vc = 120 \text{ m/min} \cdot fn = 0.25 \text{ mm/rev} \cdot ap = 120 \text{ mm} \cdot \text{wet (20 bar)}$

Tool **Insert** TPD250B (PC5300) **Holder** TPDB250-32-5-P (Drill Dia. $\varnothing = 25 \text{ mm}$)

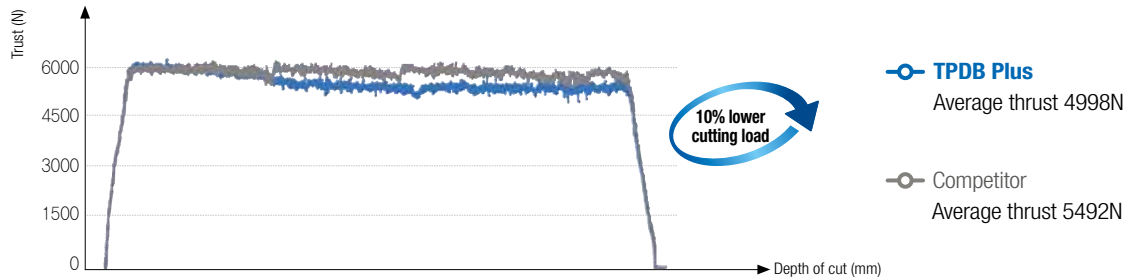

» Secured stable cutting load with excellent chip evacuation through applying low cutting resistance cutting edge and high helix flutes.

Surface finish

Workpiece Alloy steel (42CrMo4, HRC22)

Cutting condition $vc = 120 \text{ m/min} \cdot fn = 0.35 \text{ mm/rev} \cdot ap = 120 \text{ mm} \cdot \text{wet (20 bar)}$

Tool **Insert** TPD250B (PC5300) **Holder** TPDB250-32-5-P (Drill Dia. $\varnothing = 25 \text{ mm}$)

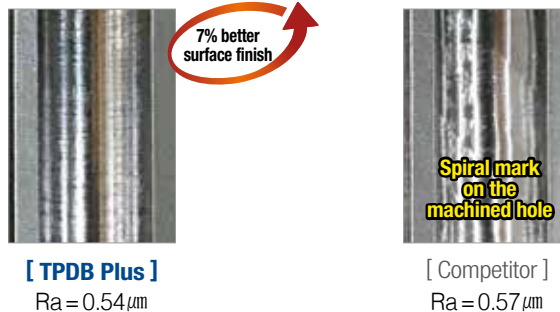

» Hohe Surface finish durch stabile Spanform und Spanabfuhr

Chip control

Workpiece Alloy steel (42CrMo4, HRC22)

Cutting condition $vc = 120 \text{ m/min} \cdot fn = 0.35 \text{ mm/rev} \cdot ap = 120 \text{ mm} \cdot \text{wet (20 bar)}$

Tool **Insert** TPD250B (PC5300) **Holder** TPDB250-32-5-P (Drill Dia. $\varnothing = 25 \text{ mm}$)

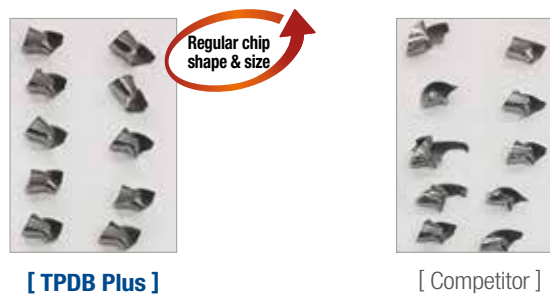

» Regular chip shape

TPDB Plus - Performance evaluation

Machining precision

Workpiece Alloy steel (42CrMo4, HRC22)

Cutting condition $vc = 90/120$ m/min · $fn = 0.25/0.35$ mm/rev · $ap = 120$ mm · wet (20 bar)

Tool **Insert** TPD250B (PC5300) **Holder** TPDB250-32-5-P (Drill Dia. $\varnothing = 25$ mm)

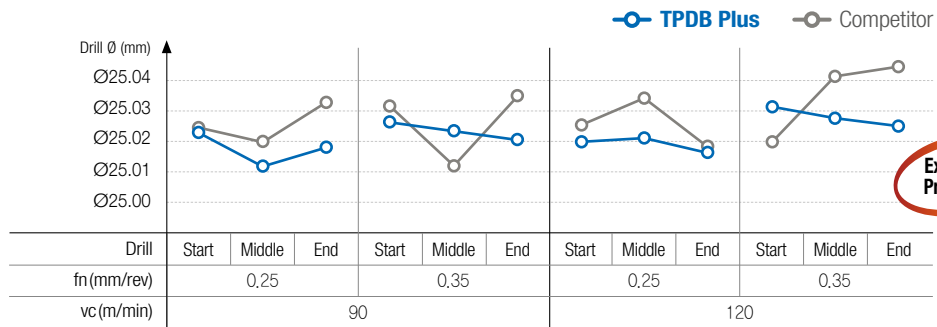
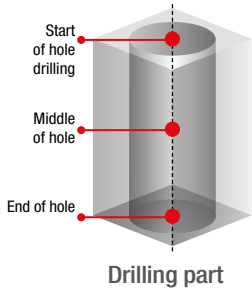

Excellent Precision

» High precision cutting due to stable chip evacuation

Wear resistance

Workpiece Alloy steel (42CrMo4, HRC22)

Cutting condition $vc = 100$ m/min · $fn = 0.3$ mm/rev · $ap = 100$ mm · wet (30 bar)

Tool **Insert** TPD250B (PC5300) **Holder** TPDB250-32-5-P (Drill Dia. $\varnothing = 25$ mm)



[TPDB Plus]



[Competitor]

» Improved built up edge and chipping resistance lead stable wear on TPDB Plus insert's edge and obtain longer max. tool life.

Workpiece Carbon steel (C45, HRC18)

Cutting condition $vc = 100$ m/min · $fn = 0.3$ mm/rev · $ap = 100$ mm · wet (30 bar)

Tool **Insert** TPD250B (PC5335) **Holder** TPDB250-32-5-P (Drill Dia. $\varnothing = 25$ mm)



[TPDB Plus]



[Competitor]

» Sharper cutting edge than competitor's improves built up edge resistance and tool life.

TPDB Plus - Grade features

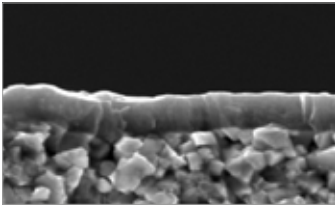

PC5300

- Applying PVD coating with high hardness and stability in machining at high temperature
- Stable Drilling due to high cutting edge strength and excellent chipping resistance
- Optimal grade for Drilling alloy Steel and Cast iron

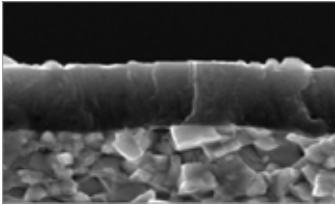

PC5335

- Applying PVD coating with high toughness and excellent lubrication
- Coating layer highly adhering to substrate
- Optimal grade for general structural Carbon steel (FE360B, etc.) and machine structural Carbon steel (C45, etc.) machining

Recommended Drilling method (10D, 12D)

Machine a pilot hole 1.5xD



- Machine a pilot hole with the depth of cut as 0.5D and at 30% lower speed using a 1.5D or 3D Drill.

Start drilling

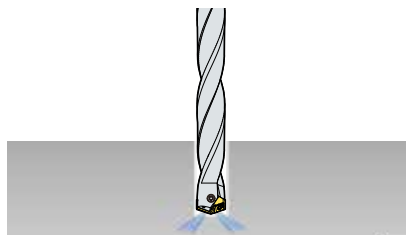

- After the pilot hole, replace the pilot Drill to a Drill for further operation and machine in recommended cutting conditions.

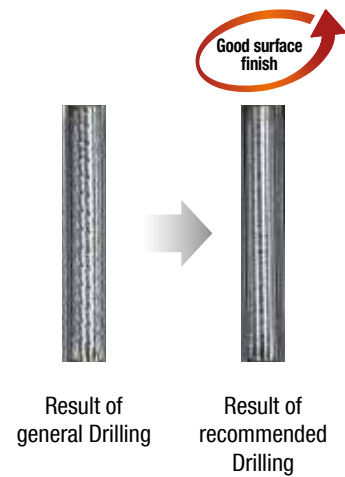

Precaution in Drilling

Angled surface



The approach angle between Drill and the workpiece at the beginning and the end should be less than 6°. Reduce the feed (fn) to 30-50% than general cutting conditions at the beginning and the end of angled surface.

Stacked plates



Gap between the plates could make wrong chip evacuation causing fracture of the Drill. Place stacked plates without any gap between each.

Plunging

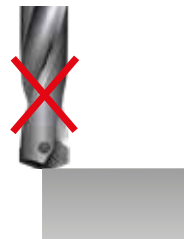

Irregular cutting resistance in plunging could cause fracture and deformation of the Drill

Boring

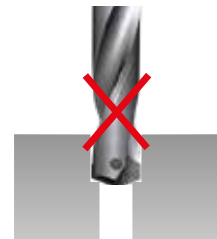

Boring is not recommended due to wear and chipping in the corner of the insert.

Checklist for the Drilling

- Workpiece clamping condition
- Rotational state of the main axial in the machining equipment
- Holder condition
- Clamped drill's Run-out : Max. 0.03 mm
- Coolant supply condition (pressure, flow rate, concentration)
- Chip evacuation condition





Coolant application system

- Adequate supply of cutting fluid at the entrance of the hole
- Minimum cutting fluid pressure: 5 bar or above
- Minimum flow rate : 5ℓ/min or above

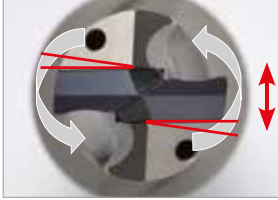
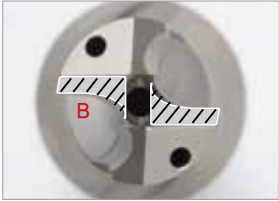

dry

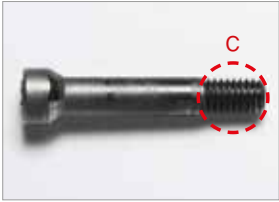
Replacement of holders and screws

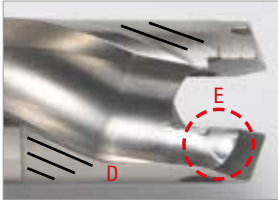
Worn part	How to check	Description
<p>Pic. 1</p> 	<p>Pic. 2</p> <p>Check the gap</p> 	<ul style="list-style-type: none"> • In case of Drilling for a long time as shown in the [Pic. 1] the 'A' part is torn and twisted due to torque. • As shown in the [Pic. 2] check the gap between the insert and the tip seat turning the clamped insert from side to side. If there is a gap between them, replace the used holder to a new one.
<p>Pic. 3</p> 	<p>Pic. 4</p> <p>Check moving</p> 	<ul style="list-style-type: none"> • The insert could move up or down due to the load on the Z-axis in Drilling over an extended period of time which causes wear on the 'B' part as shown the [Pic. 3]. • After clamping an insert, if the insert is moving or there is a gap between the insert and the tip seat as shown in the [Pic. 4] replace the used holder to a new one.
<p>Pic. 5</p> 	<p>Check moving</p> 	<ul style="list-style-type: none"> • After an extended period of use, the screw can be worn as shown in the 'C' part of [Pic. 5] which could decrease the clamping force of the insert. When the screw is worn, replace the old screw to a new one among the enclosed extras. • Spreading the grease on the screw makes it last longer.
<p>Pic. 6</p> <p>① Check the 'D' and 'E' parts as shown in the [Pic. 6].</p> <p>② Check whether the chips are getting longer or not.</p>		<ul style="list-style-type: none"> • Winding or jamming of long and tiny chips in Drilling causes wear or scratch on the 'D' part as shown in the [Pic. 6] due to chattering from machining in improper cutting conditions. In that case, reset the cutting conditions and check the Run-out before machining. • The excessive wear of the part 'E' as shown in the [Pic. 6] relating to chip curling might cause long chips.

TPDB Plus - Holder

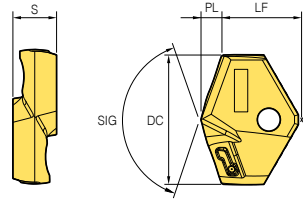
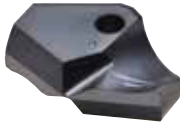

Designation	Grade		Dimension (mm)					
	PC5300	PC5335	DC	LF	PL	SIG	S	
TPD	100B	▲		10.0	6.0	1.58	140	3.5
	101B	▲		10.1	6.0	1.59	140	3.5
	102B	▲		10.2	6.0	1.61	140	3.5
	103B	▲		10.3	6.0	1.62	140	3.5
	105B	▲		10.5	5.9	1.66	140	3.5
	108B	▲		10.8	5.9	1.70	140	3.5
	110B	▲	▲	11.0	6.9	1.73	140	3.5
	111B	▲		11.1	6.9	1.75	140	3.5
	115B	▲		11.5	6.8	1.81	140	3.5
	118B	▲		11.8	6.7	1.86	140	3.5
	120B	▲	●	12.0	7.0	2.07	140	3.5
	121B	▲		12.1	7.0	2.08	140	3.5
	122B	▲		12.2	7.0	2.10	140	3.5
	123B	▲		12.3	7.0	2.12	140	3.5
	124B	▲		12.4	7.0	2.13	140	3.5
	125B	▲	●	12.5	7.0	2.15	140	3.5
	126B	▲		12.6	6.9	2.17	140	3.5
	130B	▲		13.0	7.9	2.24	140	4.0
	132B	▲		13.2	7.8	2.27	140	4.0
	135B	▲		13.5	7.8	2.32	140	4.0
	137B	▲		13.7	7.7	2.36	140	4.0
	140B	▲	▲	14.0	8.2	2.41	140	4.0
	141B	▲		14.1	8.2	2.43	140	4.0
	142B	▲		14.2	8.2	2.44	140	4.0
	143B	▲		14.3	8.1	2.46	140	4.0
	144B	▲		14.4	8.1	2.48	140	4.0
	145B	▲	●	14.5	8.1	2.50	140	4.0
	146B	▲		14.6	8.1	2.51	140	4.0
	147B	▲		14.7	8.1	2.53	140	4.0
	150B	▲	▲	15.0	8.5	2.58	140	4.0
	151B	▲		15.1	8.5	2.60	140	4.0
	152B	▲		15.2	8.5	2.62	140	4.0
	154B	▲		15.4	8.5	2.65	140	4.0
155B	▲	●	15.5	8.4	2.67	140	4.0	
157B	▲		15.7	8.4	2.70	140	4.0	
158B	▲		15.8	8.4	2.72	140	4.0	
159B	○		15.9	8.4	2.74	140	4.0	
160B	▲	●	16.0	9.4	2.75	140	5.5	
161B	▲		16.1	9.3	2.77	140	5.5	
162B	▲		16.2	9.3	2.79	140	5.5	
163B	▲		16.3	9.3	2.81	140	5.5	
164B	▲		16.4	9.3	2.82	140	5.5	
165B	▲		16.5	9.3	2.84	140	5.5	
166B	▲		16.6	9.2	2.86	140	5.5	
167B	▲		16.7	9.2	2.88	140	5.5	
170B	▲	▲	17.0	9.7	2.93	140	5.5	
171B	▲		17.1	9.7	2.94	140	5.5	

TPD inserts not listed in the range of Ø10,00 - Ø32,99 can be made to order.

▲: Stock item Europe ●: Stock item Korea ○: Production on demand

TPDB Plus - Holder

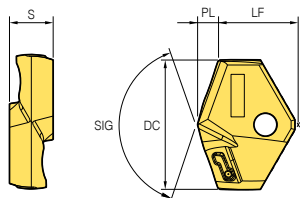
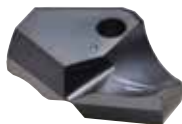

Designation	Grade		Dimension (mm)				
	PC5300	PC5335	DC	LF	PL	SIG	S
172B	▲		17.2	9.6	2.96	140	5.5
173B	●		17.3	9.6	2.98	140	5.5
174B	▲		17.4	9.6	3.00	140	5.5
175B	▲	●	17.5	9.6	3.01	140	5.5
176B	▲		17.6	9.6	3.03	140	5.5
177B	▲		17.7	9.6	3.05	140	5.5
178B	▲		17.8	9.5	3.06	140	5.5
180B	▲	▲	18.0	10.5	3.10	140	6.0
181B	▲		18.1	10.5	3.12	140	6.0
182B	▲		18.2	10.5	3.13	140	6.0
185B	▲	●	18.5	10.4	3.19	140	6.0
186B	▲	●	18.6	10.4	3.20	140	6.0
187B	▲		18.7	10.4	3.22	140	6.0
190B	▲	▲	19.0	10.8	3.27	140	6.0
191B	▲		19.1	10.8	3.29	140	6.0
192B	▲		19.2	10.8	3.31	140	6.0
193B	▲		19.3	10.8	3.32	140	6.0
195B	▲		19.5	10.7	3.36	140	6.0
196B	▲		19.6	10.7	3.37	140	6.0
197B	▲		19.7	10.7	3.39	140	6.0
198B	▲		19.8	10.7	3.41	140	6.0
199B	▲		19.9	10.7	3.43	140	6.0
200B	▲	▲	20.0	11.7	3.44	140	6.5
201B	▲		20.1	11.6	3.46	140	6.5
202B	▲		20.2	11.6	3.48	140	6.5
204B	▲		20.4	11.6	3.51	140	6.5
205B	▲		20.5	11.6	3.53	140	6.5
206B	▲		20.6	11.6	3.55	140	6.5
210B	▲	▲	21.0	12.0	3.62	140	6.5
211B	▲		21.1	12.0	3.63	140	6.5
212B	▲		21.2	12.0	3.65	140	6.5
213B	▲		21.3	11.9	3.67	140	6.5
215B	▲		21.5	11.9	3.70	140	6.5
217B	▲		21.7	11.9	3.74	140	6.5
219B	▲		21.9	11.8	3.77	140	6.5
220B	▲	▲	22.0	12.3	3.79	140	7.0
222B	▲		22.2	12.3	3.82	140	7.0
223B	▲		22.3	12.3	3.84	140	7.0
225B	▲		22.5	12.2	3.87	140	7.0
227B	▲		22.7	12.2	3.91	140	7.0
230B	▲		23.0	12.6	3.96	140	7.0
235B	▲		23.5	12.6	4.05	140	7.0
237B	▲		23.7	12.5	4.08	140	7.0
240B	▲	▲	24.0	13.0	4.13	140	7.5
242B	▲		24.2	12.9	4.17	140	7.5
244B	▲		24.4	12.9	4.20	140	7.5
245B	▲		24.5	12.9	4.22	140	7.5

TPD

TPD inserts not listed in the range of Ø10,00 - Ø32,99 can be made to order.

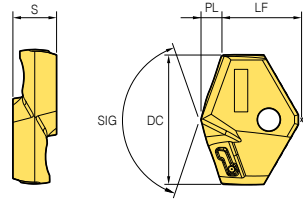
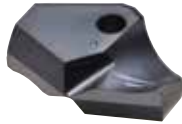

▲: Stock item Europe ●: Stock item Korea ○: Production on demand

TPDB Plus - Holder



Designation	Grade		Dimension (mm)					
	PC5300	PC5335	DC	LF	PL	SIG	S	
TPD	247B	▲	24.7	12.9	4.25	140	7.5	
	250B	▲	▲	25.0	13.2	4.43	140	7.5
	251B	▲	●	25.1	13.2	4.44	140	7.5
	252B	▲		25.2	13.1	4.46	140	7.5
	253B	▲	●	25.3	13.1	4.48	140	7.5
	255B	▲		25.5	13.1	4.52	140	7.5
	256B	▲		25.6	13.0	4.53	140	7.5
	258B	▲		25.8	13.0	4.57	140	7.5
	259B	▲		25.9	13.0	4.59	140	7.5
	260B	▲	▲	26.0	13.5	4.60	140	8.5
	262B	▲		26.2	13.5	4.64	140	8.5
	265B	▲		26.5	13.4	4.69	140	8.5
	270B	▲		27.0	14.3	4.78	140	8.5
	275B	▲		27.5	14.2	4.87	140	8.5
	280B	▲		28.0	15.1	4.96	140	9.5
	285B	▲		28.5	15.1	5.05	140	9.5
	290B	▲		29.0	15.5	5.13	140	9.5
	295B	▲		29.5	15.4	5.22	140	9.5
300B	▲		30.0	15.6	5.46	140	10.0	
310B	▲		31.0	16.0	5.64	140	10.0	
320B	▲		32.0	16.3	5.82	140	10.0	
329B	▲		32.9	16.1	5.99	140	10.0	

Parts

Designation	Drill Dia. Ø DC (mm)	Screw 	Wrench 	Torque (N · m)	
TPD	100B - 129B	10,0 - 12,9	FTNB0209-P	TW06P	0,4
	130B - 149B	13,0 - 14,9	FTNB02512-P	TW07S	0,8
	150B - 179B	15,0 - 17,9	FTNB02514-P	TW07S	0,8
	180B - 199B	18,0 - 19,9	FTNB0316-P	TW09S	1,2
	200B - 239B	20,0 - 23,9	FTNB0319	TW09S	1,2
	240B - 259B	24,0 - 25,9	FTNB03522	TW15S	3,0
	260B - 279B	26,0 - 27,9	FTNB03524	TW15S	3,0
	280B - 299B	28,0 - 29,9	FTNB0426	TW15S	3,0
	300B - 329B	30,0 - 32,9	FTNB0528	TW20-100	4,0

TPD inserts not listed in the range of Ø10,00 - Ø32,99 can be made to order.

▲: Stock item Europe ●: Stock item Korea ○: Production on demand

TPDB-P - 3D

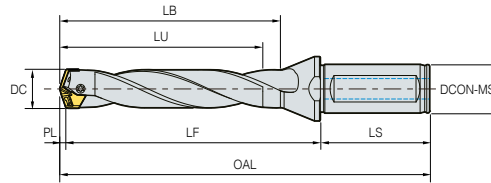

(mm)

Designation	Stock	DC	DCON-MS	LU	LF	LB	LS	OAL	PL	Insert
100-16-3-P	▲	10.0 - 10.4	16.0	31.58	47.02	37.08	48.0	96.6	1.58	TPD100B - 104B
105-16-3-P	▲	10.5 - 10.9	16.0	33.16	47.94	38.91	48.0	97.6	1.66	TPD105B - 109B
110-16-3-P	▲	11.0 - 11.4	16.0	34.73	49.97	40.73	48.0	99.7	1.73	TPD110B - 114B
115-16-3-P	▲	11.5 - 11.9	16.0	36.31	50.89	42.56	48.0	100.7	1.81	TPD115B - 119B
120-16-3-P	▲	12.0 - 12.4	16.0	38.07	53.83	44.57	48.0	103.9	2.07	TPD120B - 124B
125-16-3-P	▲	12.5 - 12.9	16.0	39.65	55.75	46.40	48.0	105.9	2.15	TPD125B - 129B
130-16-3-P	▲	13.0 - 13.4	16.0	41.24	59.06	48.24	48.0	109.3	2.24	TPD130B - 134B
135-16-3-P	▲	13.5 - 13.9	16.0	42.82	60.98	50.07	48.0	111.3	2.32	TPD135B - 139B
140-16-3-P	▲	14.0 - 14.4	16.0	44.41	63.09	51.91	48.0	113.5	2.41	TPD140B - 144B
145-16-3-P	▲	14.5 - 14.9	16.0	46.00	66.00	53.75	48.0	116.5	2.50	TPD145B - 149B
150-20-3-P	▲	15.0 - 15.4	20.0	47.58	68.12	55.58	50.0	120.7	2.58	TPD150B - 154B
155-20-3-P	▲	15.5 - 15.9	20.0	49.17	70.03	57.42	50.0	122.7	2.67	TPD155B - 159B
160-20-3-P	▲	16.0 - 16.4	20.0	50.75	72.15	59.25	50.0	124.9	2.75	TPD160B - 164B
165-20-3-P	▲	16.5 - 16.9	20.0	52.34	74.06	61.09	50.0	126.9	2.84	TPD165B - 169B
170-20-3-P	▲	17.0 - 17.4	20.0	53.93	77.17	62.93	50.0	130.1	2.93	TPD170B - 174B
175-20-3-P	▲	17.5 - 17.9	20.0	55.51	79.09	64.76	50.0	132.1	3.01	TPD175B - 179B
180-25-3-P	▲	18.0 - 18.4	25.0	57.10	81.10	66.60	56.0	140.2	3.10	TPD180B - 184B
185-25-3-P	▲	18.5 - 18.9	25.0	58.69	83.01	68.44	56.0	142.2	3.19	TPD185B - 189B
190-25-3-P	▲	19.0 - 19.4	25.0	60.27	86.03	70.27	56.0	145.3	3.27	TPD190B - 194B
195-25-3-P	▲	19.5 - 19.9	25.0	61.86	87.94	72.11	56.0	147.3	3.36	TPD195B - 199B
200-25-3-P	▲	20.0 - 20.4	25.0	63.44	90.06	73.94	56.0	149.5	3.44	TPD200B - 204B
205-25-3-P	▲	20.5 - 20.9	25.0	65.03	91.97	75.78	56.0	151.5	3.53	TPD205B - 209B
210-25-3-P	▲	21.0 - 21.4	25.0	66.62	91.08	77.62	60.0	154.7	3.62	TPD210B - 214B
215-25-3-P	▲	21.5 - 21.9	25.0	68.20	93.00	79.45	60.0	156.7	3.70	TPD215B - 219B
220-25-3-P	▲	22.0 - 22.4	25.0	69.79	95.11	81.29	60.0	158.9	3.79	TPD220B - 224B
225-25-3-P	▲	22.5 - 22.9	25.0	71.37	97.03	83.12	60.0	160.9	3.87	TPD225B - 229B
230-25-3-P	▲	23.0 - 23.4	25.0	72.96	100.14	84.96	60.0	164.1	3.96	TPD230B - 234B
235-25-3-P	▲	23.5 - 23.9	25.0	74.55	102.05	86.80	60.0	166.1	4.05	TPD235B - 239B
240-32-3-P	▲	24.0 - 24.4	32.0	76.13	108.17	88.63	60.0	172.3	4.13	TPD240B - 244B
245-32-3-P	▲	24.5 - 24.9	32.0	77.72	110.08	90.47	60.0	174.3	4.22	TPD245B - 249B
250-32-3-P	▲	25.0 - 25.4	32.0	79.43	113.07	92.43	60.0	177.5	4.43	TPD250B - 254B
255-32-3-P	▲	25.5 - 25.9	32.0	81.02	114.98	94.27	60.0	179.5	4.52	TPD255B - 259B
260-32-3-P	▲	26.0 - 26.9	32.0	82.60	117.10	96.10	60.0	181.7	4.60	TPD260B - 269B
270-32-3-P	▲	27.0 - 27.9	32.0	85.78	122.12	99.78	60.0	186.9	4.78	TPD270B - 279B
280-32-3-P	▲	28.0 - 28.9	32.0	88.96	126.04	103.46	60.0	191.0	4.96	TPD280B - 289B
290-32-3-P	▲	29.0 - 29.9	32.0	92.13	131.07	107.13	60.0	196.2	5.13	TPD290B - 299B
300-32-3-P	▲	30.0 - 30.9	32.0	95.46	133.94	110.96	60.0	199.4	5.46	TPD300B - 309B
310-32-3-P	▲	31.0 - 31.9	32.0	98.64	138.96	114.64	60.0	204.6	5.64	TPD310B - 319B
320-32-3-P	▲	32.0 - 32.9	32.0	101.82	140.98	118.32	60.0	206.8	5.82	TPD320B - 329B

TPDB

▲: Stock item Europe ●: Stock item Korea ○: Production on demand

TPDB-P - 5D

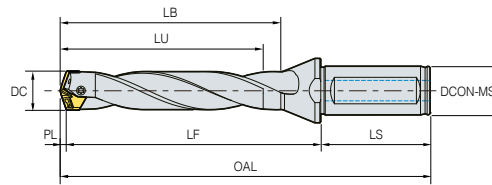

(mm)

Designation	Stock	DC	DCON-MS	LU	LF	LB	LS	OAL	PL	Insert
100-16-5-P	▲	10.0 - 10.4	16.0	51.58	67.02	57.08	48.0	116.6	1.58	TPD100B - 104B
105-16-5-P	▲	10.5 - 10.9	16.0	54.16	68.94	59.91	48.0	118.6	1.66	TPD105B - 109B
110-16-5-P	▲	11.0 - 11.4	16.0	56.73	71.97	62.73	48.0	121.7	1.73	TPD110B - 114B
115-16-5-P	▲	11.5 - 11.9	16.0	59.31	74.89	65.56	48.0	124.7	1.81	TPD115B - 119B
120-16-5-P	▲	12.0 - 12.4	16.0	62.07	78.03	68.57	48.0	128.1	2.07	TPD120B - 124B
125-16-5-P	▲	12.5 - 12.9	16.0	64.65	81.05	71.40	48.0	131.2	2.15	TPD125B - 129B
130-16-5-P	▲	13.0 - 13.4	16.0	67.24	85.06	74.24	48.0	135.3	2.24	TPD130B - 134B
135-16-5-P	▲	13.5 - 13.9	16.0	69.82	88.08	77.07	48.0	138.4	2.32	TPD135B - 139B
140-16-5-P	▲	14.0 - 14.4	16.0	72.41	91.09	79.91	48.0	141.5	2.41	TPD140B - 144B
145-16-5-P	▲	14.5 - 14.9	16.0	75.00	95.10	82.75	48.0	145.6	2.50	TPD145B - 149B
150-20-5-P	▲	15.0 - 15.4	20.0	77.58	98.12	85.58	50.0	150.7	2.58	TPD150B - 154B
155-20-5-P	▲	15.5 - 15.9	20.0	80.17	101.03	88.42	50.0	153.7	2.67	TPD155B - 159B
160-20-5-P	▲	16.0 - 16.4	20.0	82.75	104.15	91.25	50.0	156.9	2.75	TPD160B - 164B
165-20-5-P	▲	16.5 - 16.9	20.0	85.34	107.06	94.09	50.0	159.9	2.84	TPD165B - 169B
170-20-5-P	▲	17.0 - 17.4	20.0	87.93	111.17	96.93	50.0	164.1	2.93	TPD170B - 174B
175-20-5-P	▲	17.5 - 17.9	20.0	90.51	114.09	99.76	50.0	167.1	3.01	TPD175B - 179B
180-25-5-P	▲	18.0 - 18.4	25.0	93.10	117.10	102.60	56.0	176.2	3.10	TPD180B - 184B
185-25-5-P	▲	18.5 - 18.9	25.0	95.69	120.01	105.44	56.0	179.2	3.19	TPD185B - 189B
190-25-5-P	▲	19.0 - 19.4	25.0	98.27	124.03	108.27	56.0	183.3	3.27	TPD190B - 194B
195-25-5-P	▲	19.5 - 19.9	25.0	100.86	126.94	111.11	56.0	186.3	3.36	TPD195B - 199B
200-25-5-P	▲	20.0 - 20.4	25.0	103.44	130.06	113.94	56.0	189.5	3.44	TPD200B - 204B
205-25-5-P	▲	20.5 - 20.9	25.0	106.03	132.97	116.78	56.0	192.5	3.53	TPD205B - 209B
210-25-5-P	▲	21.0 - 21.4	25.0	108.62	133.08	119.62	60.0	196.7	3.62	TPD210B - 214B
215-25-5-P	▲	21.5 - 21.9	25.0	111.20	136.00	122.45	60.0	199.7	3.70	TPD215B - 219B
220-25-5-P	▲	22.0 - 22.4	25.0	113.79	139.11	125.29	60.0	202.9	3.79	TPD220B - 224B
225-25-5-P	▲	22.5 - 22.9	25.0	116.37	142.03	128.12	60.0	205.9	3.87	TPD225B - 229B
230-25-5-P	▲	23.0 - 23.4	25.0	118.96	146.14	130.96	60.0	210.1	3.96	TPD230B - 234B
235-25-5-P	▲	23.5 - 23.9	25.0	121.55	149.05	133.80	60.0	213.1	4.05	TPD235B - 239B
240-32-5-P	▲	24.0 - 24.4	32.0	124.13	156.17	136.63	60.0	220.3	4.13	TPD240B - 244B
245-32-5-P	▲	24.5 - 24.9	32.0	126.72	159.08	139.47	60.0	223.3	4.22	TPD245B - 249B
250-32-5-P	▲	25.0 - 25.4	32.0	129.43	163.07	142.43	60.0	227.5	4.43	TPD250B - 254B
255-32-5-P	▲	25.5 - 25.9	32.0	132.02	165.98	145.27	60.0	230.5	4.52	TPD255B - 259B
260-32-5-P	▲	26.0 - 26.9	32.0	134.60	169.10	148.10	60.0	233.7	4.60	TPD260B - 269B
270-32-5-P	▲	27.0 - 27.9	32.0	139.78	176.12	153.78	60.0	240.9	4.78	TPD270B - 279B
280-32-5-P	▲	28.0 - 28.9	32.0	144.96	182.04	159.46	60.0	247.0	4.96	TPD280B - 289B
290-32-5-P	▲	29.0 - 29.9	32.0	150.13	189.07	165.13	60.0	254.2	5.13	TPD290B - 299B
300-32-5-P	▲	30.0 - 30.9	32.0	155.46	193.94	170.96	60.0	259.4	5.46	TPD300B - 309B
310-32-5-P	▲	31.0 - 31.9	32.0	160.64	200.96	176.64	60.0	266.6	5.64	TPD310B - 319B
320-32-5-P	▲	32.0 - 32.9	32.0	165.82	204.98	182.32	60.0	270.8	5.82	TPD320B - 329B

TPDB

▲: Stock item Europe ●: Stock item Korea ○: Production on demand

TPDB-P - 8D

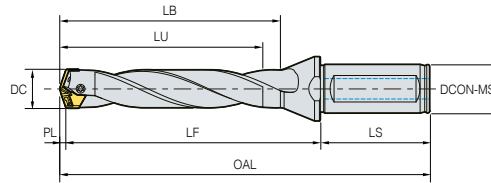

(mm)

Designation	Stock	DC	DCON-MS	LU	LF	LB	LS	OAL	PL	Insert
100-16-8-P	▲	10.0 - 10.4	16.0	81.58	97.02	87.08	48.0	146.6	1.58	TPD100B - 104B
105-16-8-P	▲	10.5 - 10.9	16.0	85.66	100.94	91.41	48.0	150.6	1.66	TPD105B - 109B
110-16-8-P	▲	11.0 - 11.4	16.0	89.73	104.97	95.73	48.0	154.7	1.73	TPD110B - 114B
115-16-8-P	▲	11.5 - 11.9	16.0	93.81	108.89	100.06	48.0	158.7	1.81	TPD115B - 119B
120-16-8-P	▲	12.0 - 12.4	16.0	98.07	114.03	104.57	48.0	164.1	2.07	TPD120B - 124B
125-16-8-P	▲	12.5 - 12.9	16.0	102.15	118.55	108.90	48.0	168.7	2.15	TPD125B - 129B
130-16-8-P	▲	13.0 - 13.4	16.0	106.24	124.06	113.24	48.0	174.3	2.24	TPD130B - 134B
135-16-8-P	▲	13.5 - 13.9	16.0	110.32	128.58	117.57	48.0	178.9	2.32	TPD135B - 139B
140-16-8-P	▲	14.0 - 14.4	16.0	114.41	133.09	121.91	48.0	183.5	2.41	TPD140B - 144B
145-16-8-P	▲	14.5 - 14.9	16.0	118.50	138.60	126.25	48.0	189.1	2.50	TPD145B - 149B
150-20-8-P	▲	15.0 - 15.4	20.0	122.58	143.12	130.58	50.0	195.7	2.58	TPD150B - 154B
155-20-8-P	▲	15.5 - 15.9	20.0	126.67	147.53	134.92	50.0	200.2	2.67	TPD155B - 159B
160-20-8-P	▲	16.0 - 16.4	20.0	130.75	152.15	139.25	50.0	204.9	2.75	TPD160B - 164B
165-20-8-P	▲	16.5 - 16.9	20.0	134.84	156.56	143.59	50.0	209.4	2.84	TPD165B - 169B
170-20-8-P	▲	17.0 - 17.4	20.0	138.93	162.17	147.93	50.0	215.1	2.93	TPD170B - 174B
175-20-8-P	▲	17.5 - 17.9	20.0	143.01	166.59	152.26	50.0	219.6	3.01	TPD175B - 179B
180-25-8-P	▲	18.0 - 18.4	25.0	147.10	171.10	156.60	56.0	230.2	3.10	TPD180B - 184B
185-25-8-P	▲	18.5 - 18.9	25.0	151.19	175.51	160.94	56.0	234.7	3.19	TPD185B - 189B
190-25-8-P	▲	19.0 - 19.4	25.0	155.27	181.03	165.27	56.0	240.3	3.27	TPD190B - 194B
195-25-8-P	▲	19.5 - 19.9	25.0	159.36	185.44	169.61	56.0	244.8	3.36	TPD195B - 199B
200-25-8-P	▲	20.0 - 20.4	25.0	163.44	190.06	173.94	56.0	249.5	3.44	TPD200B - 204B
205-25-8-P	▲	20.5 - 20.9	25.0	167.53	194.47	178.28	56.0	254.0	3.53	TPD205B - 209B
210-25-8-P	▲	21.0 - 21.4	25.0	171.62	196.08	182.62	60.0	259.7	3.62	TPD210B - 214B
215-25-8-P	▲	21.5 - 21.9	25.0	175.70	200.50	186.95	60.0	264.2	3.70	TPD215B - 219B
220-25-8-P	▲	22.0 - 22.4	25.0	179.79	205.11	191.29	60.0	268.9	3.79	TPD220B - 224B
225-25-8-P	▲	22.5 - 22.9	25.0	183.87	209.73	195.62	60.0	273.6	3.87	TPD225B - 229B
230-25-8-P	▲	23.0 - 23.4	25.0	187.96	215.14	199.96	60.0	279.1	3.96	TPD230B - 234B
235-25-8-P	▲	23.5 - 23.9	25.0	192.05	219.55	204.30	60.0	283.6	4.05	TPD235B - 239B
240-32-8-P	▲	24.0 - 24.4	32.0	196.13	228.17	208.63	60.0	292.3	4.13	TPD240B - 244B
245-32-8-P	▲	24.5 - 24.9	32.0	200.22	232.58	212.97	60.0	296.8	4.22	TPD245B - 249B
250-32-8-P	▲	25.0 - 25.4	32.0	204.43	238.07	217.43	60.0	302.5	4.43	TPD250B - 254B
255-32-8-P	▲	25.5 - 25.9	32.0	208.52	242.48	221.77	60.0	307.0	4.52	TPD255B - 259B
260-32-8-P	▲	26.0 - 26.9	32.0	212.60	247.10	226.10	60.0	311.7	4.60	TPD260B - 269B
270-32-8-P	▲	27.0 - 27.9	32.0	220.78	257.12	234.78	60.0	321.9	4.78	TPD270B - 279B
280-32-8-P	▲	28.0 - 28.9	32.0	228.96	266.04	243.46	60.0	331.0	4.96	TPD280B - 289B
290-32-8-P	▲	29.0 - 29.9	32.0	237.13	276.07	252.13	60.0	341.2	5.13	TPD290B - 299B
300-32-8-P	▲	30.0 - 30.9	32.0	245.46	283.94	260.96	60.0	349.4	5.46	TPD300B - 309B
310-32-8-P	▲	31.0 - 31.9	32.0	253.64	293.96	269.64	60.0	359.6	5.64	TPD310B - 319B
320-32-8-P	▲	32.0 - 32.9	32.0	261.82	300.98	278.32	60.0	366.8	5.82	TPD320B - 329B

TPDB

▲: Stock item Europe ●: Stock item Korea ○: Production on demand

TPDB-P - 10D

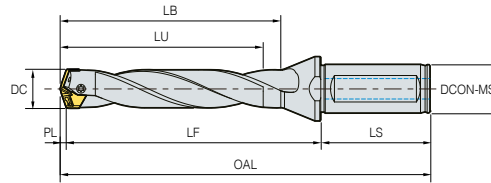

(mm)

Designation	Stock	DC	DCON-MS	LU	LF	LB	LS	OAL	PL	Insert
100-16-10-P	●	10.0 - 10.4	16.0	101.58	117.02	107.08	48.0	166.6	1.58	TPD100B - 104B
105-16-10-P	●	10.5 - 10.9	16.0	106.66	121.94	112.41	48.0	171.6	1.66	TPD105B - 109B
110-16-10-P	●	11.0 - 11.4	16.0	111.73	126.97	117.73	48.0	176.7	1.73	TPD110B - 114B
115-16-10-P	●	11.5 - 11.9	16.0	116.81	131.89	123.06	48.0	181.7	1.81	TPD115B - 119B
120-16-10-P	▲	12.0 - 12.4	16.0	122.07	138.03	128.57	48.0	188.1	2.07	TPD120B - 124B
125-16-10-P	▲	12.5 - 12.9	16.0	127.15	143.55	133.90	48.0	193.7	2.15	TPD125B - 129B
130-16-10-P	▲	13.0 - 13.4	16.0	132.24	150.06	139.24	48.0	200.3	2.24	TPD130B - 134B
135-16-10-P	●	13.5 - 13.9	16.0	137.32	155.58	144.57	48.0	205.9	2.32	TPD135B - 139B
140-16-10-P	▲	14.0 - 14.4	16.0	142.41	161.09	149.91	48.0	211.5	2.41	TPD140B - 144B
145-16-10-P	●	14.5 - 14.9	16.0	147.50	167.60	155.25	48.0	218.1	2.50	TPD145B - 149B
150-20-10-P	●	15.0 - 15.4	20.0	152.58	173.12	160.58	50.0	225.7	2.58	TPD150B - 154B
155-20-10-P	●	15.5 - 15.9	20.0	157.67	178.53	165.92	50.0	231.2	2.67	TPD155B - 159B
160-20-10-P	▲	16.0 - 16.4	20.0	162.75	184.15	171.25	50.0	236.9	2.75	TPD160B - 164B
165-20-10-P	▲	16.5 - 16.9	20.0	167.84	189.56	176.59	50.0	242.4	2.84	TPD165B - 169B
170-20-10-P	●	17.0 - 17.4	20.0	172.93	196.17	181.93	50.0	249.1	2.93	TPD170B - 174B
175-20-10-P	▲	17.5 - 17.9	20.0	178.01	201.59	187.26	50.0	254.6	3.01	TPD175B - 179B
180-25-10-P	▲	18.0 - 18.4	25.0	183.10	207.10	192.60	56.0	266.2	3.10	TPD180B - 184B
185-25-10-P	●	18.5 - 18.9	25.0	188.19	212.51	197.94	56.0	271.7	3.19	TPD185B - 189B
190-25-10-P	●	19.0 - 19.4	25.0	193.27	219.03	203.27	56.0	278.3	3.27	TPD190B - 194B
195-25-10-P	●	19.5 - 19.9	25.0	198.36	224.44	208.61	56.0	283.8	3.36	TPD195B - 199B
200-25-10-P	▲	20.0 - 20.4	25.0	203.44	230.06	213.94	56.0	289.5	3.44	TPD200B - 204B
205-25-10-P	●	20.5 - 20.9	25.0	208.53	235.47	219.28	56.0	295.0	3.53	TPD205B - 209B
210-25-10-P	▲	21.0 - 21.4	25.0	213.62	238.08	224.62	60.0	301.7	3.62	TPD210B - 214B
215-25-10-P	●	21.5 - 21.9	25.0	218.70	243.50	229.95	60.0	307.2	3.70	TPD215B - 219B
220-25-10-P	▲	22.0 - 22.4	25.0	223.79	249.11	235.29	60.0	312.9	3.79	TPD220B - 224B
225-25-10-P	●	22.5 - 22.9	25.0	228.87	254.73	240.62	60.0	318.6	3.87	TPD225B - 229B
230-25-10-P	●	23.0 - 23.4	25.0	233.96	261.14	245.96	60.0	325.1	3.96	TPD230B - 234B
235-25-10-P	●	23.5 - 23.9	25.0	239.05	266.55	251.30	60.0	330.6	4.05	TPD235B - 239B
240-32-10-P	●	24.0 - 24.4	32.0	244.13	276.17	256.63	60.0	340.3	4.13	TPD240B - 244B
245-32-10-P	●	24.5 - 24.9	32.0	249.22	281.58	261.97	60.0	345.8	4.22	TPD245B - 249B
250-32-10-P	●	25.0 - 25.4	32.0	254.43	288.07	267.43	60.0	352.5	4.43	TPD250B - 254B
255-32-10-P	●	25.5 - 25.9	32.0	259.52	293.48	272.77	60.0	358.0	4.52	TPD255B - 259B
260-32-10-P	▲	26.0 - 26.9	32.0	264.60	299.10	278.10	60.0	363.7	4.60	TPD260B - 269B
270-32-10-P	●	27.0 - 27.9	32.0	274.78	311.12	288.78	60.0	375.9	4.78	TPD270B - 279B
280-32-10-P	●	28.0 - 28.9	32.0	284.96	322.04	299.46	60.0	387.0	4.96	TPD280B - 289B
290-32-10-P	●	29.0 - 29.9	32.0	295.13	334.07	310.13	60.0	399.2	5.13	TPD290B - 299B
300-32-10-P	●	30.0 - 30.9	32.0	305.46	343.94	320.96	60.0	409.4	5.46	TPD300B - 309B
310-32-10-P	●	31.0 - 31.9	32.0	315.64	355.96	331.64	60.0	421.6	5.64	TPD310B - 319B
320-32-10-P	●	32.0 - 32.9	32.0	325.82	364.98	342.32	60.0	430.8	5.82	TPD320B - 329B

TPDB

▲: Stock item Europe ●: Stock item Korea ○: Production on demand

TPDB-P - 12D

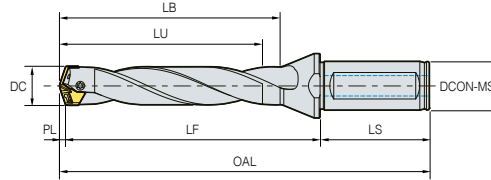

(mm)

Designation	Stock	DC	DCON-MS	LU	LF	LB	LS	OAL	PL	Insert
100-16-12-P	●	10.0 - 10.4	16.0	121.58	137.02	127.08	48.0	186.6	1.58	TPD100B - 104B
105-16-12-P	●	10.5 - 10.9	16.0	127.66	142.94	133.41	48.0	192.6	1.66	TPD105B - 109B
110-16-12-P	●	11.0 - 11.4	16.0	133.73	148.97	139.73	48.0	198.7	1.73	TPD110B - 114B
115-16-12-P	●	11.5 - 11.9	16.0	139.81	154.89	146.06	48.0	204.7	1.81	TPD115B - 119B
120-16-12-P	▲	12.0 - 12.4	16.0	146.07	162.03	152.57	48.0	212.1	2.07	TPD120B - 124B
125-16-12-P	▲	12.5 - 12.9	16.0	152.15	168.55	158.90	48.0	218.7	2.15	TPD125B - 129B
130-16-12-P	▲	13.0 - 13.4	16.0	158.24	176.06	165.24	48.0	226.3	2.24	TPD130B - 134B
135-16-12-P	●	13.5 - 13.9	16.0	164.32	182.58	171.57	48.0	232.9	2.32	TPD135B - 139B
140-16-12-P	▲	14.0 - 14.4	16.0	170.41	189.09	177.91	48.0	239.5	2.41	TPD140B - 144B
145-16-12-P	●	14.5 - 14.9	16.0	176.50	196.60	184.25	48.0	247.1	2.50	TPD145B - 149B
150-20-12-P	●	15.0 - 15.4	20.0	182.58	203.12	190.58	50.0	255.7	2.58	TPD150B - 154B
155-20-12-P	●	15.5 - 15.9	20.0	188.67	209.53	196.92	50.0	262.2	2.67	TPD155B - 159B
160-20-12-P	▲	16.0 - 16.4	20.0	194.75	216.15	203.25	50.0	268.9	2.75	TPD160B - 164B
165-20-12-P	▲	16.5 - 16.9	20.0	200.84	222.56	209.59	50.0	275.4	2.84	TPD165B - 169B
170-20-12-P	●	17.0 - 17.4	20.0	206.93	230.17	215.93	50.0	283.1	2.93	TPD170B - 174B
175-20-12-P	▲	17.5 - 17.9	20.0	213.01	236.59	222.26	50.0	289.6	3.01	TPD175B - 179B
180-25-12-P	▲	18.0 - 18.4	25.0	219.10	243.10	228.60	56.0	302.2	3.10	TPD180B - 184B
185-25-12-P	●	18.5 - 18.9	25.0	225.19	249.51	234.94	56.0	308.7	3.19	TPD185B - 189B
190-25-12-P	●	19.0 - 19.4	25.0	231.27	257.03	241.27	56.0	316.3	3.27	TPD190B - 194B
195-25-12-P	●	19.5 - 19.9	25.0	237.36	263.44	247.61	56.0	322.8	3.36	TPD195B - 199B
200-25-12-P	▲	20.0 - 20.4	25.0	243.44	270.06	253.94	56.0	329.5	3.44	TPD200B - 204B
205-25-12-P	●	20.5 - 20.9	25.0	249.53	276.47	260.28	56.0	336.0	3.53	TPD205B - 209B
210-25-12-P	▲	21.0 - 21.4	25.0	255.62	280.08	266.62	60.0	343.7	3.62	TPD210B - 214B
215-25-12-P	●	21.5 - 21.9	25.0	261.70	286.50	272.95	60.0	350.2	3.70	TPD215B - 219B
220-25-12-P	▲	22.0 - 22.4	25.0	267.79	293.11	279.29	60.0	356.9	3.79	TPD220B - 224B
225-25-12-P	●	22.5 - 22.9	25.0	273.87	299.73	285.62	60.0	363.6	3.87	TPD225B - 229B
230-25-12-P	●	23.0 - 23.4	25.0	279.96	307.14	291.96	60.0	371.1	3.96	TPD230B - 234B
235-25-12-P	●	23.5 - 23.9	25.0	286.05	313.55	298.30	60.0	377.6	4.05	TPD235B - 239B
240-32-12-P	●	24.0 - 24.4	32.0	292.13	324.17	304.63	60.0	388.3	4.13	TPD240B - 244B
245-32-12-P	●	24.5 - 24.9	32.0	298.22	330.58	310.97	60.0	394.8	4.22	TPD245B - 249B
250-32-12-P	●	25.0 - 25.4	32.0	304.43	338.07	317.43	60.0	402.5	4.43	TPD250B - 254B
255-32-12-P	●	25.5 - 25.9	32.0	310.52	344.48	323.77	60.0	409.0	4.52	TPD255B - 259B
260-32-12-P	▲	26.0 - 26.9	32.0	316.60	351.10	330.10	60.0	415.7	4.60	TPD260B - 269B
270-32-12-P	●	27.0 - 27.9	32.0	328.78	365.12	342.78	60.0	429.9	4.78	TPD270B - 279B
280-32-12-P	●	28.0 - 28.9	32.0	340.96	378.04	355.46	60.0	443.0	4.96	TPD280B - 289B
290-32-12-P	●	29.0 - 29.9	32.0	353.13	392.07	368.13	60.0	457.2	5.13	TPD290B - 299B
300-32-12-P	●	30.0 - 30.9	32.0	365.46	403.94	380.96	60.0	469.4	5.46	TPD300B - 309B
310-32-12-P	●	31.0 - 31.9	32.0	377.64	417.96	393.64	60.0	483.6	5.64	TPD310B - 319B
320-32-12-P	●	32.0 - 32.9	32.0	389.82	428.98	406.32	60.0	494.8	5.82	TPD320B - 329B

TPDB

▲: Stock item Europe ●: Stock item Korea ○: Production on demand

Code system

Insert

TPD	360	B	DS	PC5300
Top solid Piercing Drill	Drill dia. Ø 360: Ø36.0 mm	Insert type B: Blade type	Margin shape DS: Double margin shape	Grade PC5300

Holder

TPD	B	360	40	5	P
Top solid Piercing Drill	Holder type B: Blade type	Drill dia. Ø 360: Ø36.0 mm	Shank dia. Ø 40: Ø 40.0 mm	Aspect ratio L/D 3D, 5D, 8D	PlusDrill

Features

- A curved linear insert with high helix angle applied holder, which has low cutting load and excellent chip handling performance.
- Excellent clamping stability with a specially designed clamping section and 2 screws-on clamping methods.
- Improved wear resistance and durability through special surface treatment.

Screw-on clamping

- Good clamping stability due to 2 screws-on clamping method

Cutting edge shape for low cutting resistance

- Less cutting load and better chip control

Applied double margin

- Increased cutting stability
- Better surface finish on inner wall of the hole
- Higher precision of hole size

Applied key preventing insert misalignment

- High precision of clamping

Special surface treatment

- High durability of the holder

2-stufige Form

- Sorgt für eine gute Spanabfuhr

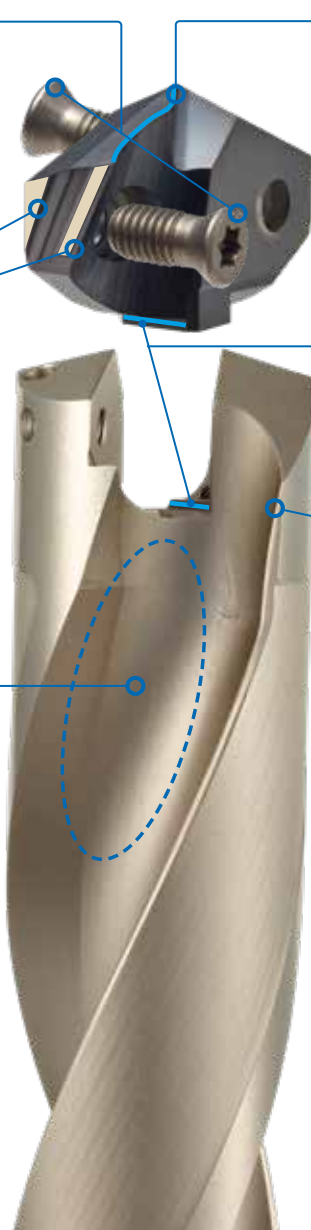

TPDB-DS - How to clamp an insert



① Clean the tip seat.

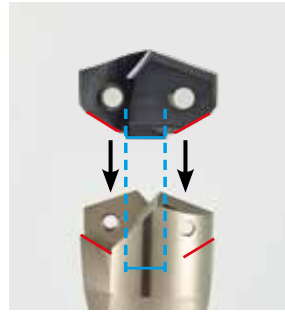

② Put an insert in.



③ Lightly press the insert while screwing to prevent it from rotating.



④ Clamp a screw partially just like in the case of **A** and **B** and prevent it from wobbling.

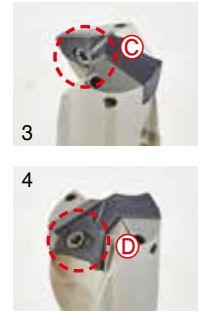

⑤ Complete the partially the screw in the order of **C** and **D**.



Recommended cutting conditions

ISO	Workpiece			Trust (N/mm ²)	Brinell Hardness (HB)	Grade	vc (m/min)	Aspect ratio = 3D, 5D	
	Workpiece material	KS	ISO					fn (mm/rev)	
P	Carbon steel	C = 0.10 - 0.25%	SM15C SM25C	C15 C25	1500	90 - 200	PC5300	80 - 140	0.4 - 0.25
		C = 0.25 - 0.55%	SM35C SM45C	C35 C45	1600	125 - 225	PC5300	80 - 140	0.4 - 0.25
		C = 0.55 - 0.80%	SM58C	C60	1700	150 - 250	PC5300	70 - 130	0.4 - 0.25
	Alloy steel ≤ 5%	Non-hardened	SCM440	42CrMo4	1700	180	PC5300	80 - 130	0.45 - 0.25
		Hardened and Tempered	SCM445	-	2050	350	PC5300	60 - 110	0.45 - 0.25
	Alloy steel > 5%	Annealed	STD11	-	1950	200	PC5300	60 - 100	0.4 - 0.25
		Tool steel	STD61	X40CrMoV5-1	3000	352	PC5300	50 - 90	0.35 - 0.2
K	Gray cast iron	GC250 GC350	250 350	900	150 - 230	PC5300	80 - 140	0.45 - 0.25	
	Ductile cast iron	GCD400 GCD500 GCD600	400-15 150-10 600-3	870	160 - 260	PC5300	70 - 130	0.45 - 0.25	

For 8D, reduce the recommended cutting conditions by 20% to 30% from the machining depth to 0.5D during the entry then proceed with the above-mentioned cutting conditions. For interrupted machining, reduce the feed to 0.1 to 0.15 in the vicinity of the interrupted cutting area.

TPDB-DS - Performance evaluation

Machining precision

Workpiece Alloy steel (42CrMo4, HRC22)
Cutting condition $vc = 70/90/110 \text{ m/min} \cdot fn = 0.25/0.35 \text{ mm/rev} \cdot ap = 150 \text{ mm} \cdot \text{wet (20 bar)}$
Tool **Insert** TPD360B-DS (PC5300) **Holder** TPDB360-40-5-P (Drill Dia. $\varnothing = 36 \text{ mm}$)

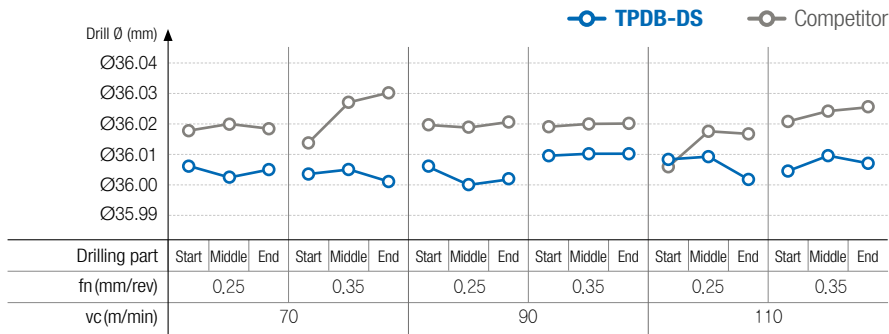
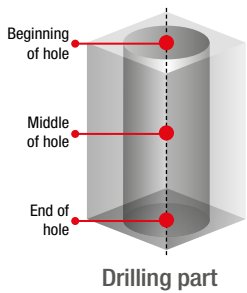

Good precision

» Improved machining precision through double margin and stable chip evacuation.

Wear resistance

Workpiece Alloy steel (42CrMo4, HRC22)
Cutting condition $vc = 90 \text{ m/min} \cdot fn = 0.3 \text{ mm/rev} \cdot ap = 150 \text{ mm} \cdot \text{wet (20 bar)}$
Tool **Insert** TPD360B-DS (PC5300) **Holder** TPDB360-40-5-P (Drill Dia. $\varnothing = 36 \text{ mm}$)

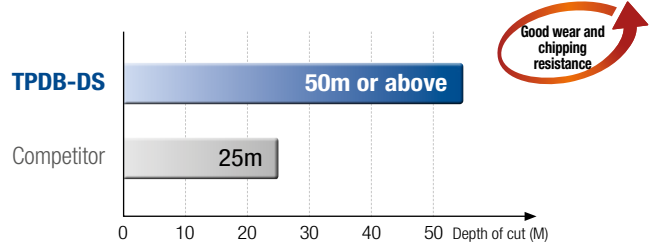

Good wear and chipping resistance

» Increased maximum tool life with more stable chipping resistance compared to the competitor's

Cutting surface finish / chip surface finish

Workpiece Alloy steel (42CrMo4, HRC22)
Cutting condition $vc = 90 \text{ m/min} \cdot fn = 0.35 \text{ mm/rev} \cdot ap = 150 \text{ mm} \cdot \text{wet (20 bar)}$
Tool **Insert** TPD360B-DS(PC5300) **Holder** TPDB360-40-5-P (Drill Dia. $\varnothing = 36 \text{ mm}$)



» Good surface finish due to stable chip formation and effective chip evacuation

Precaution in Drilling

Angled surface



The approach angle between Drill and the workpiece at the beginning and the end should be less than 6° .
Reduce the feed (f_n) to 30-50% than general cutting conditions at the beginning and the end of angled surface.

Stacked plates



Gap between the plates could make wrong chip evacuation causing fracture of the Drill.
Place stacked plates without any gap between each.

Plunging

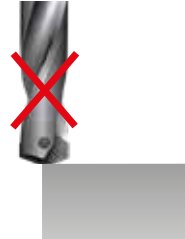

Irregular cutting resistance in plunging could cause fracture and deformation of the Drill.

Boring

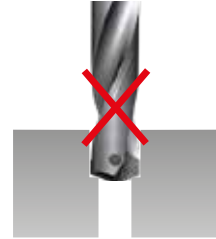

Boring is not recommended due to wear and chipping in the corner of the insert.

Drilling checklist

- Workpiece clamping condition
- Rotational state of the main axial in the machining equipment
- Holder condition
- Clamped drill's Run-out : Max. 0.03 mm
- Coolant supply condition (pressure, flow rate, concentration)
- Chip evacuation condition

Coolant application system

- Adequate supply of cutting fluid at the entrance of the hole
- Minimum cutting fluid pressure: 5 bar or above
- Minimum flow rate: 5 ℓ /min or above



Dry

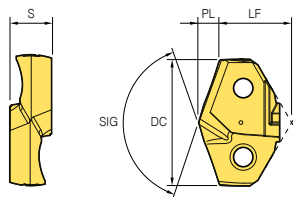
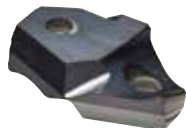

TPDB-DS - Insert



(mm)

Designation	Grade	DC	LF	PL	SIG	S	
	PC5300						
TPD	330B-DS	▲	33,0	18,16	5,38	140	10,5
	335B-DS	○	33,5	18,06	5,48	140	10,5
	340B-DS	▲	34,0	18,54	5,55	140	11,0
	345B-DS	○	34,5	18,47	5,64	140	11,0
	350B-DS	▲	35,0	19,47	5,71	140	11,5
	355B-DS	○	35,5	19,38	5,80	140	11,5
	360B-DS	▲	36,0	20,40	5,87	140	11,5
	365B-DS	○	36,5	20,31	5,97	140	11,5
	370B-DS	▲	37,0	20,79	6,04	140	12,0
	375B-DS	○	37,5	20,70	6,13	140	12,0
	380B-DS	▲	38,0	21,62	6,20	140	12,0
	385B-DS	○	38,5	21,53	6,29	140	12,0
	390B-DS	▲	39,0	22,01	6,36	140	12,5
	395B-DS	○	39,5	21,92	6,46	140	12,5

Parts

Designation	Drill Dia. Ø DC (mm)	Screw 	Wrench 	
TPD	330B-DS - 339B-DS	33,0 - 33,9	FTKA0410	TW15S
	340B-DS - 349B-DS	34,0 - 34,9	FTKA0410	TW15S
	350B-DS - 359B-DS	35,0 - 35,9	FTKA0410	TW15S
	360B-DS - 369B-DS	36,0 - 36,9	FTNC04511	TW20S
	370B-DS - 379B-DS	37,0 - 37,9	FTNC04511	TW20S
	380B-DS - 389B-DS	38,0 - 38,9	FTNA0511	TW20S
	390B-DS - 399B-DS	39,0 - 39,9	FTNA0511	TW20S

TPD inserts not listed in the range of Ø33,00 - Ø39,99 can be made to order.

▲: Stock item Europe ●: Stock item Korea ○: Production on demand

TPDB-DS - 3D / 5D / 8D

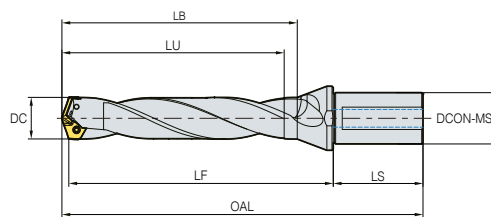

(mm)

Designation	Stock	DC	DCON-MS	LU	LF	LB	LS	OAL	PL	Insert
330-40-3-P	▲	33,0 - 33,9	40	104,4	140,3	117,6	70	215,7	5,38	TPD330B - 339B-DS
340-40-3-P	▲	34,0 - 34,9	40	107,5	144,4	121,1	70	219,9	5,55	TPD340B - 349B-DS
350-40-3-P	▲	35,0 - 35,9	40	110,7	148,5	124,7	70	224,2	5,71	TPD350B - 359B-DS
360-40-3-P	▲	36,0 - 36,9	40	113,9	152,6	128,3	70	228,5	5,87	TPD360B - 369B-DS
370-40-3-P	▲	37,0 - 37,9	40	117,0	156,7	131,8	70	232,7	6,04	TPD370B - 379B-DS
380-40-3-P	▲	38,0 - 38,9	40	120,2	160,8	135,4	70	237,0	6,20	TPD380B - 389B-DS
390-40-3-P	▲	39,0 - 39,9	40	123,4	164,9	139,0	70	241,3	6,36	TPD390B - 399B-DS
330-40-5-P	▲	33,0 - 33,9	40	170,4	206,3	183,6	70	281,7	5,38	TPD330B - 339B-DS
340-40-5-P	▲	34,0 - 34,9	40	175,5	212,4	189,1	70	287,9	5,55	TPD340B - 349B-DS
350-40-5-P	▲	35,0 - 35,9	40	180,7	218,5	194,7	70	294,2	5,71	TPD350B - 359B-DS
TPDB 360-40-5-P	▲	36,0 - 36,9	40	185,9	224,6	200,3	70	300,5	5,87	TPD360B - 369B-DS
370-40-5-P	▲	37,0 - 37,9	40	191,0	230,7	205,8	70	306,7	6,04	TPD370B - 379B-DS
380-40-5-P	▲	38,0 - 38,9	40	196,2	236,8	211,4	70	313,0	6,20	TPD380B - 389B-DS
390-40-5-P	▲	39,0 - 39,9	40	201,4	242,9	217,0	70	319,3	6,36	TPD390B - 399B-DS
330-40-8-P	○	33,0 - 33,9	40	269,4	305,3	282,6	70	380,7	5,38	TPD330B - 339B-DS
340-40-8-P	○	34,0 - 34,9	40	277,5	314,4	291,1	70	389,9	5,55	TPD340B - 349B-DS
350-40-8-P	○	35,0 - 35,9	40	285,7	323,5	299,7	70	399,2	5,71	TPD350B - 359B-DS
360-40-8-P	○	36,0 - 36,9	40	293,9	332,6	308,3	70	408,5	5,87	TPD360B - 369B-DS
370-40-8-P	○	37,0 - 37,9	40	302,0	341,7	316,8	70	417,7	6,04	TPD370B - 379B-DS
380-40-8-P	○	38,0 - 38,9	40	310,2	350,8	325,4	70	427,0	6,20	TPD380B - 389B-DS
390-40-8-P	○	39,0 - 39,9	40	318,4	359,9	334,0	70	436,3	6,36	TPD390B - 399B-DS

★: If you order a precise machining specification, we can supply this.

▲: Stock item Europe ●: Stock item Korea ○: Production on demand

Code system

Insert

TPD	200	B	P	H	PC340UL
Top solid Piercing Drill	Drill dia. Ø 200: Ø20.0 mm	Insert type B: Blade type	Workpiece P: Steel	H-Beam	Grade PC340UL

Holder 3D / 4D

TPD	BP	220	25S	3	H
Top solid Piercing Drill	Holder type B: Blade type P: Plus	Drill dia. Ø 220: Ø22.0 mm	Shank dia. Ø 25: Ø 25 mm S: Straight shaft (Weldon)	Aspect ratio L/D 3D	H-Beam

Holder 5D / 8D

TPD	BP	220	25	545	5	H
Top solid Piercing Drill	Holder type B: Blade type P: Plus	Drill dia. Ø 220: Ø 22.0 mm	Shank dia. Ø 25: Ø 25 mm	Depth of cut Available cutting depth max: 54.5 mm	Aspect ratio L/D 5D, 8D	H-Beam

Features

- High precision clamping system - High precision clamping due highly precise grinding and auto-centering
- Screw on clamping system - Easy to replace insert
- Edge design with excellent centering - Low cutting load and good chip control
- High durability holder - Improved wear resistance and durability with special surface treatment implementation
- Holder with good chip evacuation - Good chip evacuation and reduced cutting load with high helix angle
- Optimally designed oil hole - Long tool life

Insert features

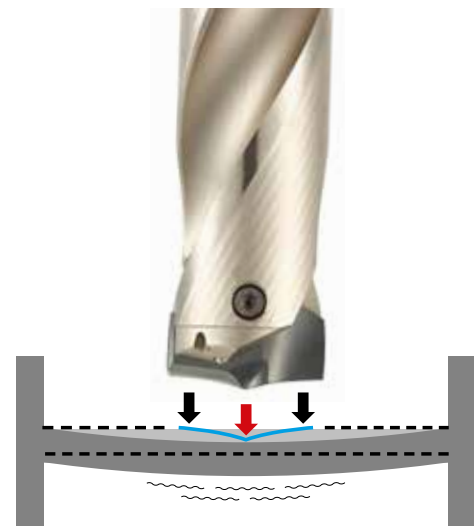
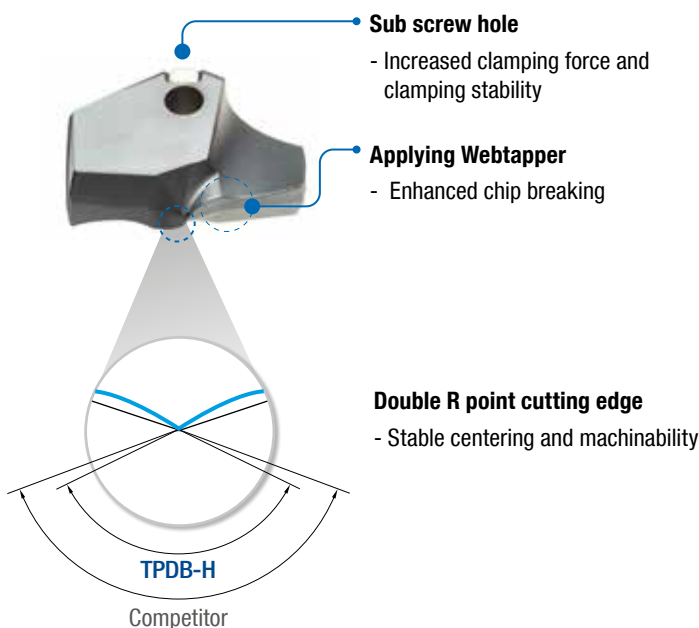

- ↓ Applied Double R point edge design is optimized for excellent centering and stable machinability.
- ↓ Machinability and productivity are improved by minimizing both workpiece's bending and chipping at edge corner section.

TPDB-H - Holder features

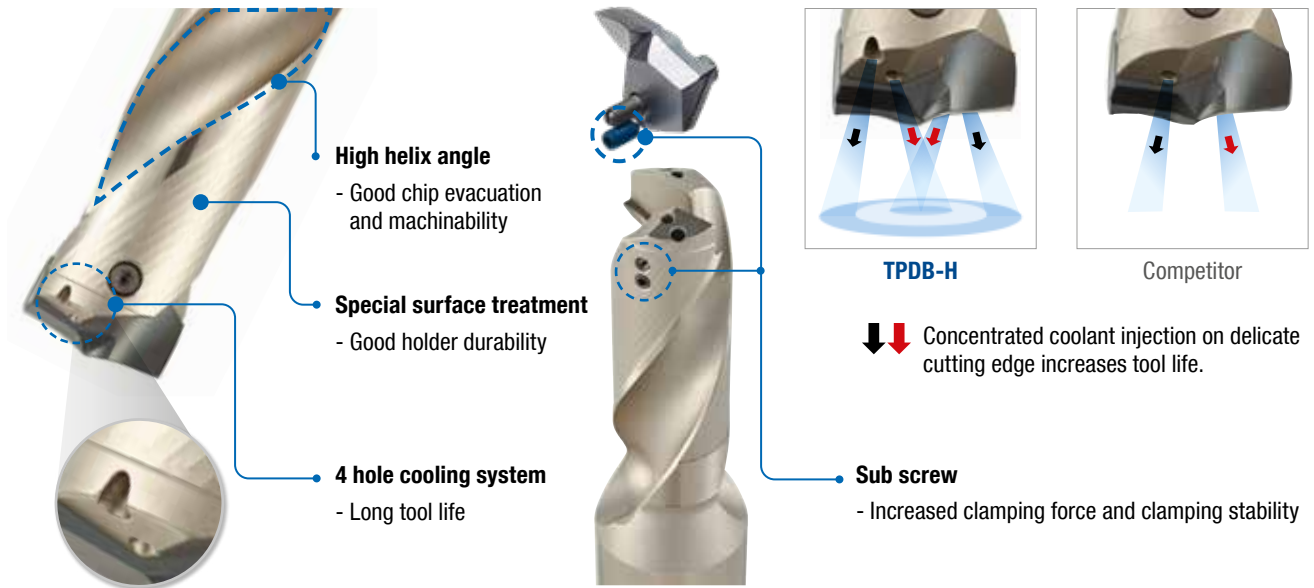

Grade features

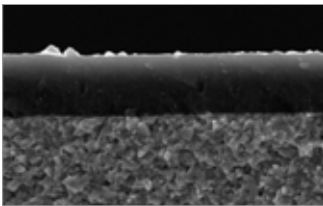

PC340UL

- Substrate with high toughness and excellent fracture resistance
- PVD coating technology with high lubricity and resistance to weld build-up
- High wear resistance and stable machining with excellent surface roughness

Performance evaluation

Chip control

Workpiece	Carbon steel (SM355A, HRC20)
Cutting condition	vc = 80 m/min · fn = 0,20 mm/rev ap = 30 mm · wet
Tool	Insert TP240BP-H (PC340UL) Holder TPDBP240-32S-4-H (Drill dia. Ø = 24 mm)



TPDB-H



Competitor

Wear resistance

Workpiece	Carbon steel (SM355A, HRC20)
Cutting condition	vc = 80 m/min · fn = 0,23 mm/rev ap = 50 mm · wet
Tool	Insert TP240BP-H (PC340UL) Holder TPDBP240-32S-4-H (Drill dia. Ø = 24 mm)





TPDB-H

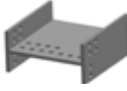

Competitor

TPDB-H - Workpiece and recommended cutting conditions

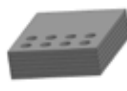
ISO	Workpiece			Yield Strength (Mpa, min)	Brinell Hardness (HB)	Grade	vc (m/min)	Aspect ratio (L/D) = 3D, 4D, 5D, 8D	
	Workpiece material	KS	AISI					fn (mm/rev)	
								Ø14 - Ø21,9	Ø22 - Ø30,9
P	H-Beam		SS275 (SS400*) SM355 (SM490*) SHN355 (SHN490*)	A36 A572	275 355 355 (t≤16)	PC340UL	60 - 75	0.25 - 0.2	0.3 - 0.2
	Angle								
	Plate								
	Plate (Stacked)								

* : Old symbol

Precaution in Drilling

Angled surface

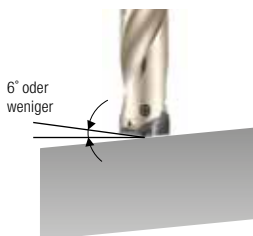

The approach angle between Drill and the workpiece at the beginning and the end should be less than 6°. Reduce the feed (fn) to 30-50% than general cutting conditions at the beginning and the end of angled surface.

Stacked plates



Gap between the plates could make wrong chip evacuation causing fracture of the Drill. Place stacked plates without any gap between each.

Plunging



Irregular cutting resistance in plunging could cause fracture and deformation of the Drill.

Boring



Boring is not recommended.

TPDB-H - Performance evaluation

Carbon steel (SM355)



Cutting condition	$vc = 47 \text{ m/min} \cdot fn = 0,24 \text{ mm/rev} \cdot ap = 50 \text{ mm} \cdot \text{Wet}$
Tool	Insert TPD240BP-H (PC340UL)
	Holder TPDBP240-32S-4-H (Drill dia. $\varnothing = 24 \text{ mm}$)
Tool life	64 m (Normal wear)

» Stable chip evacuation ensures tool life as 60 m in even machining with over 40 mm thickness.

Carbon steel (SM355)



Cutting condition	$vc = 80 \text{ m/min} \cdot fn = 0,27 \text{ mm/rev} \cdot ap = 25 \text{ mm} \cdot \text{Wet}$
Tool	Insert TPD220BP-H (PC340UL)
	Holder TPDBP220-25S-4-H (Drill dia. $\varnothing = 22 \text{ mm}$)
Tool life	41 m (Normal wear)

» High speed and high feed machining saves machining hours.

Carbon steel (SS275)



Cutting condition	$vc = 70 \text{ m/min} \cdot fn = 0,23 \text{ mm/rev} \cdot ap = 30 \text{ mm} \cdot \text{Wet}$
Tool	Insert TPD260BP-H (PC340UL)
	Holder TPDBP260-32S-4-H (Drill dia. $\varnothing = 26 \text{ mm}$)
Tool life	35 m (Normal wear)

» Stable machinability and long tool life are realized in machining various workpieces such as SM355, SS275, SHN355 etc.

Carbon steel (SM355)



Cutting condition	$vc = 56 \text{ m/min} \cdot fn = 0,31 \text{ mm/rev} \cdot ap = 40 \text{ mm} \cdot \text{Wet}$
Tool	Insert TPD270BP-H (PC340UL)
	Holder TPDBP270-32S-4-H (Drill dia. $\varnothing = 26 \text{ mm}$)
Tool life	47 m (Normal wear)

» Minimized cutting load in horizontal machining ensures high quality machining.

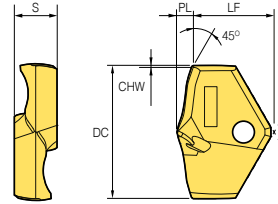
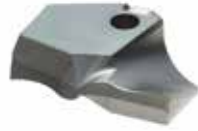

TPDB-H - Insert



(mm)

Designation	Grade	DC	LF	PL	S	CHW	
	PC340UL						
TPD	140BP-H	▲	14.0	9.45	1.17	4.0	0.05
	150BP-H	○	15.0	9.83	1.26	4.0	0.05
	160BP-H	▲	16.0	10.73	1.39	5.5	0.07
	170BP-H	○	17.0	11.14	1.48	5.5	0.07
	180BP-H	▲	18.0	12.15	1.51	6.0	0.07
	190BP-H	○	19.0	12.54	1.60	6.0	0.07
	200BP-H	▲	20.0	13.45	1.67	6.5	0.07
	210BP-H	○	21.0	13.86	1.76	6.5	0.07
	220BP-H	▲	22.0	14.54	1.89	7.0	0.09
	230BP-H	○	23.0	14.70	1.94	7.0	0.09
	240BP-H	▲	24.0	15.56	2.02	7.5	0.09
	250BP-H	○	25.0	15.98	2.10	7.5	0.09
	260BP-H	▲	26.0	16.35	2.20	8.5	0.09
	270BP-H	●	27.0	17.43	2.28	8.5	0.11
	280BP-H	▲	28.0	18.26	2.32	9.5	0.11
	290BP-H	○	29.0	18.64	2.55	9.5	0.11
	300BP-H	▲	30.0	19.03	2.61	10.0	0.11
310BP-H	○	31.0	19.44	2.70	10.0	0.11	
320BP-H	▲	32.0	19.85	2.79	10.0	0.11	

Parts

Designation	Drill dia, Ø DC (mm)	Screw 	Wrench 	Sub screw	Sub screw wrench	
TPD	TPD140BP-H - 159BP-H	Ø14,0-Ø15,9	FTNB02512-P	TW07S	-	-
	TPD160BP-H - 179BP-H	Ø16,0-Ø17,9	FTNB02514-P	TW07S	KHMA02505	HW13LB
	TPD180BP-H - 199BP-H	Ø18,0-Ø19,9	FTNB0316-P	TW09S	KHMA02505	HW13LB
	TPD200BP-H - 239BP-H	Ø20,0-Ø23,9	FTNB0319	TW09S	KHMA0306	HW15L
	TPD240BP-H - 259BP-H	Ø24,0-Ø25,9	FTNB03522	TW15S	KHMA0308	HW15L
	TPD260BP-H - 279BP-H	Ø26,0-Ø27,9	FTNB03524	TW15S	KHMA0308	HW15L
	TPD280BP-H - 299BP-H	Ø28,0-Ø29,9	FTNB0426	TW15S	KHMA0410	HW20L
	TPD300BP-H - 329BP-H	Ø30,0-Ø32,9	FTNB0528	TW20-100	KHMA0410	HW20L

TPD inserts not listed in the range of Ø14,00 - Ø30,99 can be made to order.

▲: Stock item Europe ●: Stock item Korea ○: Production on demand

TPDB-H - 3D / 4D

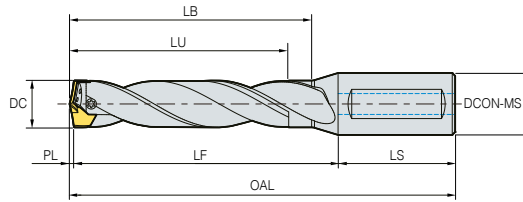

(mm)

Designation	Stock	DC	DCON-MS	LU	LF	LB	LS	OAL	PL	Insert	
TPDBP 3D	140-16S-3-H	▲	14.0-14.9	16.0	35.67	48.83	43.17	48.0	98.0	1.17	TPD140BP-H-149BP-H
	150-20S-3-H	○	15.0-15.9	20.0	38.29	52.21	46.29	50.0	103.5	1.29	TPD150BP-H-159BP-H
	160-20S-3-H	▲	16.0-16.9	20.0	40.89	55.11	49.39	50.0	106.5	1.39	TPD160BP-H-169BP-H
	170-20S-3-H	○	17.0-17.9	20.0	43.48	58.02	52.48	50.0	109.5	1.48	TPD170BP-H-179BP-H
	180-20S-3-H	▲	18.0-18.9	20.0	46.01	62.49	55.51	50.0	114.0	1.51	TPD180BP-H-189BP-H
	190-20S-3-H	○	19.0-19.9	20.0	48.60	67.40	58.60	50.0	119.0	1.60	TPD190BP-H-199BP-H
	200-25S-3-H	▲	20.0-20.9	25.0	51.17	76.33	61.67	56.0	128.0	1.67	TPD200BP-H-209BP-H
	210-25S-3-H	○	21.0-21.9	25.0	53.76	73.24	64.76	56.0	131.0	1.76	TPD210BP-H-219BP-H
	220-25S-3-H	▲	22.0-22.9	25.0	56.39	76.11	67.89	56.0	134.0	1.89	TPD220BP-H-229BP-H
	230-25S-3-H	○	23.0-23.9	25.0	58.94	79.06	70.94	56.0	137.0	1.94	TPD230BP-H-239BP-H
	240-32S-3-H	▲	24.0-24.9	32.0	61.52	84.78	74.02	60.0	146.8	2.02	TPD240BP-H-249BP-H
	250-32S-3-H	○	25.0-25.9	32.0	64.10	84.90	77.10	60.0	147.0	2.10	TPD250BP-H-259BP-H
	260-32S-3-H	▲	26.0-26.9	32.0	66.73	87.77	80.23	60.0	150.0	2.23	TPD260BP-H-269BP-H
	270-32S-3-H	●	27.0-27.9	32.0	69.28	90.72	83.28	60.0	153.0	2.28	TPD270BP-H-279BP-H
	280-32S-3-H	○	28.0-28.9	32.0	71.82	93.68	86.32	60.0	156.0	2.32	TPD280BP-H-289BP-H
	290-32S-3-H	○	29.0-29.9	32.0	74.55	96.45	89.55	60.0	159.0	2.55	TPD290BP-H-299BP-H
	300-32S-3-H	▲	30.0-30.9	32.0	77.11	99.39	92.61	60.0	162.0	2.61	TPD300BP-H-309BP-H
310-32S-3-H	○	31.0-31.9	32.0	79.70	102.30	95.70	60.0	165.0	2.70	TPD310BP-H-319BP-H	
320-32S-3-H	▲	32.0-32.9	32.0	82.29	105.21	98.79	60.0	168.0	2.79	TPD320BP-H-329BP-H	
TPDBP 4D	140-16S-4-H	○	14.0-14.9	16.0	49.67	62.83	57.17	48.0	112.0	1.17	TPD140BP-H-149BP-H
	150-20S-4-H	○	15.0-15.9	20.0	53.29	67.21	61.29	50.0	118.5	1.29	TPD150BP-H-159BP-H
	160-20S-4-H	○	16.0-16.9	20.0	56.89	71.11	65.39	50.0	122.5	1.39	TPD160BP-H-169BP-H
	170-20S-4-H	○	17.0-17.9	20.0	60.48	75.02	69.48	50.0	126.5	1.48	TPD170BP-H-179BP-H
	180-20S-4-H	○	18.0-18.9	20.0	64.01	80.49	73.51	50.0	132.0	1.51	TPD180BP-H-189BP-H
	190-20S-4-H	○	19.0-19.9	20.0	67.60	86.40	77.60	50.0	138.0	1.60	TPD190BP-H-199BP-H
	200-25S-4-H	○	20.0-20.9	25.0	71.17	96.33	81.67	56.0	148.0	1.67	TPD200BP-H-209BP-H
	210-25S-4-H	○	21.0-21.9	25.0	74.76	94.24	85.76	56.0	152.0	1.76	TPD210BP-H-219BP-H
	220-25S-4-H	●	22.0-22.9	25.0	78.39	98.11	89.89	56.0	156.0	1.89	TPD220BP-H-229BP-H
	230-25S-4-H	○	23.0-23.9	25.0	81.94	102.06	93.94	56.0	160.0	1.94	TPD230BP-H-239BP-H
	240-32S-4-H	●	24.0-24.9	32.0	85.52	108.78	98.02	60.0	170.8	2.02	TPD240BP-H-249BP-H
	250-32S-4-H	○	25.0-25.9	32.0	89.10	109.90	102.10	60.0	172.0	2.10	TPD250BP-H-259BP-H
	260-32S-4-H	●	26.0-26.9	32.0	92.73	113.77	106.23	60.0	176.0	2.23	TPD260BP-H-269BP-H
	270-32S-4-H	●	27.0-27.9	32.0	96.28	117.72	110.28	60.0	180.0	2.28	TPD270BP-H-279BP-H
	280-32S-4-H	○	28.0-28.9	32.0	99.82	121.68	114.32	60.0	184.0	2.32	TPD280BP-H-289BP-H
	290-32S-4-H	○	29.0-29.9	32.0	103.55	125.45	118.55	60.0	188.0	2.55	TPD290BP-H-299BP-H
	300-32S-4-H	○	30.0-30.9	32.0	107.11	129.39	122.61	60.0	192.0	2.61	TPD300BP-H-309BP-H
310-32S-4-H	○	31.0-31.9	32.0	110.70	133.30	126.70	60.0	196.0	2.70	TPD310BP-H-319BP-H	
320-32S-4-H	○	32.0-32.9	32.0	114.29	137.21	130.79	60.0	200.0	2.79	TPD320BP-H-329BP-H	

▲ : Stock item Europe ● : Stock item Korea ○ : Production on demand

TPDB-H - 5D

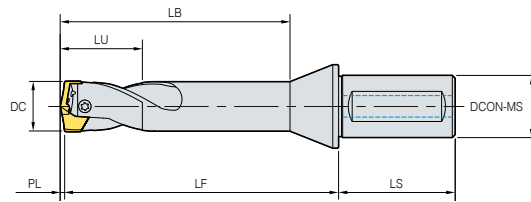

(mm)

Designation	Stock	DC	DCON-MS	LU	LF	LB	LS	OAL	PL	Insert
140-16-345-5-H	▲	14,0-14,9	16,0	35,67	83,83	71,17	48,0	133,0	1,17	TPD140BP-H-149BP-H
150-20-370-5-H	○	15,0-15,9	20,0	38,29	90,21	76,29	50,0	141,5	1,29	TPD150BP-H-159BP-H
160-20-395-5-H	▲	16,0-16,9	20,0	40,89	95,11	81,39	50,0	146,5	1,39	TPD160BP-H-169BP-H
170-20-420-5-H	○	17,0-17,9	20,0	43,48	100,02	86,48	50,0	151,5	1,48	TPD170BP-H-179BP-H
180-20-445-5-H	▲	18,0-18,9	20,0	46,01	106,49	91,51	50,0	158,0	1,51	TPD180BP-H-189BP-H
190-20-470-5-H	○	19,0-19,9	20,0	48,60	113,40	96,60	50,0	165,0	1,60	TPD190BP-H-199BP-H
200-25-495-5-H	▲	20,0-20,9	25,0	51,17	123,33	101,67	56,0	175,0	1,67	TPD200BP-H-209BP-H
210-25-520-5-H	○	21,0-21,9	25,0	53,76	122,24	106,76	56,0	180,0	1,76	TPD210BP-H-219BP-H
220-25-545-5-H	▲	22,0-22,9	25,0	56,39	127,11	111,89	56,0	185,0	1,89	TPD220BP-H-229BP-H
230-25-570-5-H	○	23,0-23,9	25,0	58,94	132,06	116,94	56,0	190,0	1,94	TPD230BP-H-239BP-H
240-32-595-5-H	▲	24,0-24,9	32,0	61,52	144,78	122,02	60,0	206,8	2,02	TPD240BP-H-249BP-H
250-32-620-5-H	○	25,0-25,9	32,0	64,10	146,90	127,10	60,0	209,0	2,10	TPD250BP-H-259BP-H
260-32-645-5-H	▲	26,0-26,9	32,0	66,73	151,77	132,23	60,0	214,0	2,23	TPD260BP-H-269BP-H
270-32-670-5-H	○	27,0-27,9	32,0	69,28	156,72	137,28	60,0	219,0	2,28	TPD270BP-H-279BP-H
280-32-695-5-H	○	28,0-28,9	32,0	71,82	161,68	142,32	60,0	224,0	2,32	TPD280BP-H-289BP-H
290-32-720-5-H	○	29,0-29,9	32,0	74,55	166,45	147,55	60,0	229,0	2,55	TPD290BP-H-299BP-H
300-32-745-5-H	▲	30,0-30,9	32,0	77,11	171,39	152,61	60,0	234,0	2,61	TPD300BP-H-309BP-H
310-32-770-5-H	○	31,0-31,9	32,0	79,70	176,30	157,70	60,0	239,0	2,70	TPD310BP-H-319BP-H
320-32-795-5-H	▲	32,0-32,9	32,0	82,29	181,21	162,79	60,0	244,0	2,79	TPD320BP-H-329BP-H

TPDBP
5D

▲ : Stock item Europe ● : Stock item Korea ○ : Production on demand

TPDB-H - 8D

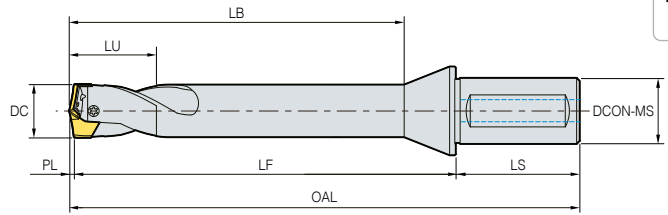

(mm)

Designation	Stock	DC	DCON-MS	LU	LF	LB	LS	OAL	PL	Insert
140-16-345-8-H	▲	14,0-14,9	16,0	35,67	125,83	113,17	48,0	175,0	1,17	TPD140BP-H-149BP-H
150-20-370-8-H	○	15,0-15,9	20,0	38,29	135,21	121,29	50,0	186,5	1,29	TPD150BP-H-159BP-H
160-20-395-8-H	▲	16,0-16,9	20,0	40,89	143,11	129,39	50,0	194,5	1,39	TPD160BP-H-169BP-H
170-20-420-8-H	○	17,0-17,9	20,0	43,48	151,02	137,48	50,0	202,5	1,48	TPD170BP-H-179BP-H
180-20-445-8-H	▲	18,0-18,9	20,0	46,01	160,49	145,51	50,0	212,0	1,51	TPD180BP-H-189BP-H
190-20-470-8-H	○	19,0-19,9	20,0	48,60	170,40	153,60	50,0	222,0	1,60	TPD190BP-H-199BP-H
200-25-495-8-H	▲	20,0-20,9	25,0	51,17	183,33	161,67	56,0	235,0	1,67	TPD200BP-H-209BP-H
210-25-520-8-H	○	21,0-21,9	25,0	53,76	185,24	169,76	56,0	243,0	1,76	TPD210BP-H-219BP-H
220-25-545-8-H	▲	22,0-22,9	25,0	56,39	193,11	177,89	56,0	251,0	1,89	TPD220BP-H-229BP-H
230-25-570-8-H	○	23,0-23,9	25,0	58,94	201,06	185,94	56,0	259,0	1,94	TPD230BP-H-239BP-H
240-32-595-8-H	○	24,0-24,9	32,0	61,52	216,78	194,02	60,0	278,8	2,02	TPD240BP-H-249BP-H
250-32-620-8-H	○	25,0-25,9	32,0	64,10	221,90	202,10	60,0	284,0	2,10	TPD250BP-H-259BP-H
260-32-645-8-H	○	26,0-26,9	32,0	66,73	229,77	210,23	60,0	292,0	2,23	TPD260BP-H-269BP-H
270-32-670-8-H	○	27,0-27,9	32,0	69,28	237,72	218,28	60,0	300,0	2,28	TPD270BP-H-279BP-H
280-32-695-8-H	○	28,0-28,9	32,0	71,82	245,68	226,32	60,0	308,0	2,32	TPD280BP-H-289BP-H
290-32-720-8-H	○	29,0-29,9	32,0	74,55	253,45	234,55	60,0	316,0	2,55	TPD290BP-H-299BP-H
300-32-745-8-H	○	30,0-30,9	32,0	77,11	261,39	242,61	60,0	324,0	2,61	TPD300BP-H-309BP-H
310-32-770-8-H	○	31,0-31,9	32,0	79,70	269,30	250,70	60,0	332,0	2,70	TPD310BP-H-319BP-H
320-32-795-8-H	○	32,0-32,9	32,0	82,29	277,21	258,79	60,0	340,0	2,79	TPD320BP-H-329BP-H

TPDBP
8D

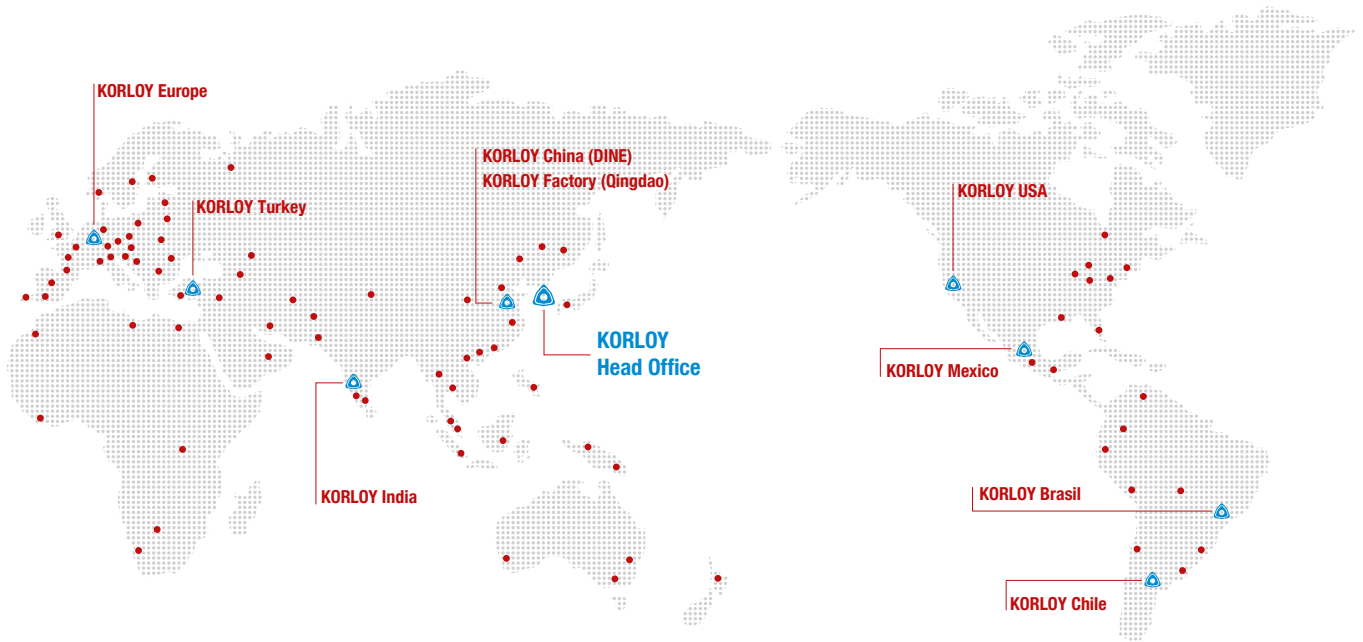

KORLOY Network

Head Office

Holystar B/D, 326, Seocho-daero,
Seocho-gu, Seoul, 06633, Korea,
Web: www.korloy.com

Cheongju Factory

55, Sandan-ro, Heungdeok-gu,
Cheongju-si, Chungcheongbuk-do,
28589, Korea

Jincheon Factory

54, Gwanghyewonsandan 2-gil,
Gwanghyewon-myeon, Jincheon-gun,
Chungcheongbuk-do, 27807, Korea

R & D Institute Seoul

Holystar B/D, 326, Seocho-daero,
Seocho-gu, Seoul, 06633, Korea

R & D Institute Cheongju

55, Sandan-ro, Heungdeok-gu,
Cheongju-si, Chungcheongbuk-do,
28589, Korea

Gurgaon Factory

Plot NO.415, Sector 8, IMT Manesar,
Gurgaon 122051, Haryana, India

KORLOY AMERICA

620, Maple Avenue, Torrance,
CA 90503, USA

KORLOY BRASIL

Av. Aruana 280, conj.12, WLC,
Alphaville, Barueri, CEP06460-010,
SP, Brasil

KORLOY CHILE

Av. Providencia 1650, Office 1009,
7500027 Providencia-Santiago, Chile

KORLOY INDIA

Ground Floor, Property No. 217, Udyog
Vihar Phase 4, Gurgaon 122016,
Haryana, India

KORLOY TURKEY

Serifali Mahallesi, Burhan Sokak NO: 34
Dudullu OSB/Umraniye/Istanbul, 34775,
Turkey

KORLOY MEXICO

Calle R. M. Clemencia Borja Taboada
522, Jurica Acueducto, 76230 Juriquilla,
Qro. Mexico

KORLOY EUROPE

Gablonzer Str. 25-27,
D-61440 Oberursel, Germany
Tel. +49-6171-27783-0
Fax +49-6171-27783-59
Mail: info@korloyeurope.com
Web: www.korloyeurope.eu

KTS - Korloy Total Service



Get our FREE App

Just download, install and use.

